

48th joint meeting of the CIDOC CRM SIG and ISO/TC46/SC4/WG9; 41st
FRBR-CIDOC CRM Harmonization Meeting.
20-23 October 2020

University of Oslo, Faculty of arts, Unit for digital documentation
Online on Zoom platform

Participants

Trond Aalberg (NTU/OSLOMET, NO); Vincent Alamertery (LAHRA/Université de Lyon, FR); (Dimitris Angelakis (ICS-FORTH, GR); Anna Aslanoglou; Chrysoula Bekiari (ICS-FORTH, GR); Maliheh Dorkhosh (Ferdowsi University Masshad, IR); Øyvind Eide (Universität zu Köln, DE); Sanaz Emami (Univeristy of Tehran, IR); Pavlos Fafalios (ICS-FORTH, GR); Achille Felicetti (PIN/University of Florence, IT); Mark Fichtner (Germanisches Nationalmuseum Nuremberg, DE); Muriel Fichtner (Universität Bayreuth, DE); Nils Geißler (Universität zu Köln, DE); Gunther Goerz (Friedrich-Alexander Uniersität, DE); Juliane Hamish (Germanisches Nationalmuseum Nuremberg, DE); Lida Harami (ICS-FORTH, GR); Gerald Hiebel (Universität Innsbruck, AT); Athina Kritsotaki (ICS-FORTH, GR); Matteo Lorenzini (ETH Zürich, CH); Philippe Michon (Canadian Heritage Information Network, CA); Massoomeh Ninkia (Kharazami University, IR); Christian-Emil Ore (University of Oslo, NO); Despina Pratikaki (ICS-FORTH, GR); Pat Riva (Concordia University, CA); Mélanie Roche (Bibliothèque Nationale de France, FR); Rob Sanderson (J Paul Getty Trust/Yale University, US); Emilio Sanfilippo (Consiglio Nazionale delle Ricerche, IT); Eleni Tsouloucha (ICS-FORTH, GR); Athanasios Velios (University of the Arts-London, UK); Maja Žumer (University of Ljubljana, SI).

Table of Contents

48th joint meeting of the CIDOC CRM SIG and ISO/TC46/SC4/WG9; 41st FRBR-CIDOC CRM Harmonization Meeting. 20-23 October 2020	1
University of Oslo, Faculty of arts, Unit for digital documentation Online on Zoom platform	1
DAY 1	6
508: FOL for P170 defines time	6
507 reformulate the scope note of P164 is temporally specified by	6
NEW ISSUE: didactic material for newly introduced properties	6
477: scope note of P101 had as general use (was use of); proper definition of terms General vs Specific.....	7
Reformulation of the scope note (HW by SdS)	7
Use of the terms “general” vs. “specific” in the CIDOC CRM	7
505 Graphics for Winckelman viewing episode	7
475: E10 transfer of custody	8
New issue: E10 Transfer of Custody -review the examples	8
406: quantification and transitivity	9
Regarding P5 and P9:	9
Regarding the transitivity of P73 has translation:	9
Overall discussion:	10
NEW ISSUE: Does the axiom of non-reflexivity follow from the definition of transitivity?	10
484: 7.0 preparation –missing examples	10
P174 starts before the end of (ends after the start of)	10
P183 ends before the start of (starts after the end of)	10
P196 defines (is defined by)	11
NEW ISSUE: How do we interpret periods in the CRM.....	12
339: References to examples of CRM text.....	12
404: modification of the scope-note of E81 Transformation and properties P123 resulted in (resulted from), P124 transformed (was transformation of)	13
503: E13 Attribute Assignment (examples)	14
514: Revision of the examples for E54 Dimension	14
From (OLD)	14
To (NEW)	15

382 where to stop documenting provenance.....	15
513: Replacement of the fictitious examples for P198.....	15
288: Issue about P81 and P82 usage	15
417: begin_of_the_begin /end_of_the_end is excluded from time range?.....	15
P81a/b.....	16
P82a/b.....	16
501: examples for P81 and P82	16
DAY 2	16
Modelling of the Paintings by CIDOC CRM -presentation by Maliheh Dorkosh (Mao)	16
Implementation of CIDOC-CRM for the Domain of Iranian Archaeology. Presenting CRM-based database Qoqnus for excavated objects from “Veshnavah, Iran” –presentation by Massoomeh Niknia (MN).....	17
Towards the Ontological Analysis and Modularization of the CRM (v.6.2.1) –presentation by Emilio M. Sanfilippo (ES).....	18
Recording Absence & Negative Properties –presentation by Athanasios Velios (TV)	19
509: Modifying Art Objects	20
486: Labels of O19 and O21	20
NEW ISSUE: reformulate the scope notes of O19, O21.....	21
448 O17 isA O18.....	21
NEW ISSUE: add graphics to the CRMsci definition	22
388: reference to the measurement of the position of things.	22
332 Properties of S10 Material Substantial	25
484: 7.0 preparation –missing examples	26
DAY 3	27
404: modification of the scope-note of E81 Transformation and properties P123 resulted in (resulted from), P124 transformed (was transformation of) –continuation.....	27
484: 7.0 preparation –missing examples	27
288: Issue about P81 and P82 usage	28
496 Types for P2 has type.....	30
495 backwards incompatibility problems.....	31
506 change the scope note for E11 Modification	32
500: Revise examples for E33 Linguistic Object	32
469: A phrase of every property of every extension	33
354: Management of issues and workflow.....	34

310: Editorial Status of CIDOC CRM and CRM Family Models	36
512: CRM Community Information for Website	36
406 return session	37
513 Replacement of the fictitious examples for P198 (return session)	38
From (OLD)	39
To (NEW)	39
473: Normal Custodian of	39
NEW ISSUE: keep or deprecate P54 and P48?	41
Background—discussions in the 48th sig meeting (issue 473)	Error! Bookmark not defined.
461: Attribute Assignment of .1 properties	41
442: Curated Holding vs Physical Thing as Aggregate vs Set	42
NEW ISSUE: aggregates/sets of things/referential collections.	43
Setting the dates/planning for the 49 th sig meeting.....	43
Appendix 1: List of abbreviated names in the text	Error! Bookmark not defined.
Appendix – Changes in scope notes	44
507: P164 temporally specified by (temporally specifies) -scope note rewrite.....	44
From (OLD):	44
To (NEW):	44
477: scope note of P101 had as general use (was use of); proper definition of terms General vs Specific.....	44
From (OLD)	44
To (NEW)	45
Issue 475: reformulate the scope note of E10 Transfer of Custody.....	46
FROM (old)	46
TO (new).....	46
404: modification of the scope-note of E81 Transformation and properties P123 resulted in (resulted from), P124 transformed (was transformation of)	47
E81 Transformation	47
P123 resulted in (resulted from)	48
P124 transformed (was transformation of)	49
503 : Attribute Assignment (examples)	49
E13 Attribute Assignment	49
P140 assigned attribute to	49
P141 assigned	49

P177 assigned property type.....	49
E14 Condition Assessment	50
P34 concerned.....	50
P35 has identified	50
Works cited	50
501: examples for P81 and P82.....	50
P81 ongoing throughout.....	50
P82 at some time within	50
506 change the scope note for E11 Modification	51
From (OLD):.....	51
To (NEW):	51
442: Curated Holding vs Physical Thing as Aggregate vs Set	52
From (OLD)	52
To (NEW)	52
List of abbreviated names.....	53

DAY 1

508: FOL for P170 defines time

GB presented the outcome of the e-vote (16 Oct 2020) regarding the addition of the axiom

P170 $(x, y) \Rightarrow P81(x, y) \wedge P82(x, y)$,

in the FOL section of the definition of P170 defines time (time is defined by), to convey the meaning that the time span in question is exactly ongoing and within the given time primitive. There were 7 votes in favor of adding the axiom, and none against.

PROPOSAL: vote on implementing the changes and closing the issue

VOTE

In favor: 7

Against: 0

Outcome: the axiom will be added to the FOL statement for P170 defines time (time is defined by).

Issue is closed.

507 reformulate the scope note of P164 is temporally specified by

MD presented the reworked scope note for P164 (HW by MD & SdS)

DISCUSSION:

GB –the scope note reads nicely. No need to go through types to explain whether an instance of E52 Time Span is phenomenal or declared, because the paths are clearly defined. Would like to see this properly explained –in an FAQ section, with diagrams etc. –once v7.1 has been released.

VOTE: to accept the reworked scope note for **P164**, discuss didactic materials.

Outcome

11: in favor,

0: against.

DECISION:

- (i) Change the scope note for P164 temporally specified by (temporally specifies) as proposed by MD & SdS. The details can be found in the [Appendix](#)
- (ii) Start a [new issue](#) on producing didactic material that needs be produced once new properties are introduced in CIDOC CRM v7.1 –like we have done for STVs. Include the use of P164 temporally specified by in said material
- (iii) **Issue is closed**

NEW ISSUE: didactic material for newly introduced properties

Upon resolving issue 507, the sig decided that it should come up with a consistent way to explain to CIDOC CRM users how to best deploy new properties. Diagrams for P164 should be part of the issue. In general, the material should draw on experience from STVs and how they were handled.

477: scope note of P101 had as general use (was use of); proper definition of terms
General vs Specific

Background:

During the 46th sig meeting in Athens, it was decided to introduce certain axioms in the FOL representation of a set of CRM properties. P101 had as general use was among said properties, and the axiom representing it was: $P101(x,y) \supset \exists z[E7(z) \wedge P16(z,x) \wedge P2(z,y)]$. It was decided that the scope note should change accordingly (to reflect the existential presupposition contributed by the axiom), and that every instance of the terms “general” vs “specific” found across the CRM would be disambiguated.

The current issue aims to accomplish both.

Reformulation of the scope note (HW by SdS)

Discussion:

The sig seemed to like better the new version (scope note AND examples) by SdS

VOTE on accepting the reformulated scope note

In favor: 8

Against: 0

Outcome: Accepted the reformulated definition, implement it for CIDOC CRM v7.1

Use of the terms “general” vs. “specific” in the CIDOC CRM

There is only one more instance that the terms “general” vs. “specific” appear in the label of a pair of properties (P20 had specific purpose (was purpose of) vs. P21 had general purpose (was purpose of)).

Decision: Do not alter these ones, very different case –P20/21 are not factual, just intentions (general or specific), we cannot deduce the existence of multiple intentions that lead up to an instance of E7 Activity.

Issue is closed

505 Graphics for Winckelman viewing episode

MD presented the original graphic representing the meeting of Winckelman and the Laocoon group.

To demonstrate how the instances of temporal entities connect things in spacetime, Martin produced another document [time and space each on an axis], where events are represented of points in space and time (defined by their coordinates). He explained how things and people interact (meet) through the events represented, all leading up to the creation of Winkelmann’s paper on ancient Greek art.

PROPOSAL: vote on including the graph [MD’s HW] in CIDOC CRM v7.1

VOTE:

In favor: 12

Against: 0

Outcome: Accept the proposal and include the STV diagram in the CIDOC CRM v7.1

PROPOSAL:

MD: to produce an animation that shows the graphic paths evolving as we have designed them in the spacetime diagram for didactic purposes?

ML: He has a task that is similar to what MD proposed, he can create the animation.

DECISION:

- (i) Include the STV diagram in the CIDOC CRM v7.1
- (ii) HW to ML to produce the animation of STVs moving

[475: E10 transfer of custody](#)

The sig reviewed the rewrite of the scope note for E10 Transfer of Custody by GB. GBs version is an update of the scope note by RS (that fixed the contradiction btw physical possession implied in the first paragraph vs. physical possession or legal custody in the second paragraph) incorporating suggestions by the sig.

The sig discussed OE's objections on the examples of E10 Transfer of Custody (more context needed). It was agreed that the example concerning the delivery of (some) paintings by Secure Deliveries Inc. to the National Gallery is much too underspecified and obscure and that it needs be reworked.

PROPOSAL:

The proposal was to accept the edited scope note as is (RS & GB) and rework the examples in a separate issue –**HW** to TV to lookup proper references for the National Gallery example; **HW** to GB to ask the Getty for other examples instantiating a transfer of custody.

VOTE: The reworked scope note and the proposal to go through the examples in a separate issue was put to a vote

7: in favor,

0: against.

Outcome: accept the new scope note for E10 Transfer of Custody to be included in 7.1.

DECISION:

- (i) The scope note for E10 Transfer of Custody changed as proposed. The details can be found in the [Appendix](#).
- (i) **Start a [new issue](#) regarding the examples of E10 Transfer of Custody:**
HW to **TV** to lookup proper references for the National Gallery example;
HW to **GB** to ask the Getty for other examples instantiating a transfer of custody
- (ii) **Issue is closed**

[New issue: E10 Transfer of Custody -review the examples](#)

Upon discussing issue 475 (changes to the scope note of E10 Transfer of Custody), the sig resolved to revise the examples of said CRM class in a separate issue.

HW to TV to lookup proper references for the National Gallery example;

HW to GB to ask the Getty for other examples instantiating a transfer of custody

406: quantification and transitivity

The sig reviewed the HW by CEO on the quantification of transitive properties. In essence, the topic of this issue revolves around the transitivity and the quantification properties of P5 consists of [D:E3 Condition State, R: E3 Condition State], P9 consists of [D:E4 Period, R: E4 Period] and P73 has translation [D: E33 Linguistic Object, R: E33 Linguistic Object].

Regarding P5 and P9:

PROPOSAL:

It was proposed that properties **P5 consists of [D: E3 Condition State, R: E3 Condition State]** and **P9 consists of [D: E4 Period, R: E4 Period]** are **transitive**, and as such:

- (a) their quantification should be set to **many-to-many**,
- (b) and that they are transitive should be defined **non-trivially** –e.g., the statement that E4 Period - P9 consists of: E4 Period, should mean that the one is a **proper subpart** of the other, resulting in the **introduction of a non-reflexivity axiom** in the definition of transitive properties as well.

VOTE: Declaring P5 and P9 transitive properties, and changing their quantification was put to a vote.

8: in favor,

0: against

Outcome: P5 and P9 will be declared transitive.

VOTE: Declaring P5 and P9 non-reflexive properties was put to a vote.

8: in favor,

0: against

Outcome: P5 and P9 will be declared non-reflexive

DECISION: a transitivity and a non-reflexivity axiom are introduced for properties P5 and P9, their quantification is set to many-to-many.

Regarding the transitivity of P73 has translation:

Discussion points:

The existence of translations as intermediate sources to other translations gives rise to the impression that P73 has translation should be declared transitive. However, what this approach fails to capture is that the relation between the original text and the (mediated) end-translation holds at the level of (F1) Work and not its (F2) Expression. At the level of work the relation between the original text and a (mediated) end-translation is more adequately represented as a derivation. May be best if LRM properties were used instead.

VOTE: to declare P73 has translation transitive and to change its quantification to *many-to-many*

In favor: 3

Against: 0

Outcome: non-decisive

DECISION: The outcome of the vote implies that there is no consensus or that the issue is not well-understood. It was agreed that the issue should be readdressed within the [48th sig meeting](#) (with more

detail -HW to CEO) and that any objections/counter-proposals should be documented by interested parties on the working document.

Overall discussion:

MD: proposed that a transitivity axiom should be added to all transitive properties and that a non-reflexivity axiom should be added to all non-reflexive properties. Properties that have part-of semantics should include a non-reflexivity axiom by default.

CEO: (counter-proposal) discuss whether the non-reflexivity follows from the definition of transitivity in a separate, new issue.

NEW ISSUE: *Does the axiom of non-reflexivity follow from the definition of transitivity?*

Upon discussing issue 406 (transitivity and quantification of properties), MD suggested that the axiom of non-reflexivity be introduced for all properties that have part-of semantics.

CEO proposed that the non-reflexivity requirement be examined separately –as part of the semantics imposed by a many-to-many quantification. HW CEO to produce a text that explains the semantics of transitivity vs non-reflexivity in the context of discussing P73 (day 3 sig).

484: 7.0 preparation –missing examples

The sig reviewed the examples proposed for the following temporal properties:

P174 starts before the end of (ends after the start of), P183 ends before the start of (starts after the end of), P196 defines (is defined by).

P174 starts before the end of (ends after the start of)

The sig did some minor editing, and voted on accepting the example below:

The settling activity of the city of Assur (Ashur) (E7) *P174 starts before the end of* The Tenth Dynasty of Egypt. (E4) [There are some 200 - 300 years differences in the chronology of the First Intermediate Period, and Assur is dated to "about 2500 BC"]

In favor: 7

Against: 0

Outcome: the example will appear on the CIDOC CRM v7.1 as is. References must be added.

P183 ends before the start of (starts after the end of)

MD proposed the following example

Troy VII (E7) *P183 ends before the start of* Troy VIII (E7) [uninhabited for some 200 years]

Before voting, the sig discussed on whether Troy VII/ Troy VIII should be an instance of E7 Activity or E4 Period.

CEO, GB: argued that if it was an activity, then it would have been carried out by an actor -we can't say that of periods, nor of Troy VII/Troy VIII.

MD: argued that Troy VII/Troy VIII would be defined by the actions of the people that lived in it. The specialization for periods is different than that.

PROPOSAL:

Since it has no bearing on the example, the vote should be split into two decisions:

- (a) accepting the example -or not
- (b) deciding over the label of the class: make Troy VII/Troy VIII an instance of E7 Activity or E4 Period?

VOTE on accepting the example:

In favor: 7

Against: 0

Outcome: the example will appear on the CIDOC CRM v7.1 as is. References must be added.

VOTE on the label of the class for Troy VII/Troy VIII:

E4 Period: 2

E7 Activity: 4

Outcome: Since there is no strong majority, MD argued that the example should appear with the more generic label (E4 Period) in CIDOC CRM v7.1 and the discussion regarding the interpretation of periods (as settlements and administration of the communities involved) in the CRM be carried over to a new issue. Everyone was in agreement.

[P196 defines \(is defined by\)](#)

The sig reviewed the example provided by SdS:

H.M.S. Temeraire (E22) *defines* the spacetime volume of H.M.S. Temeraire [it was built, during 1798, in Chatham and destroyed, during 1838, in Rotherhithe] (Willis 2010)

Willis, S. (2010). *The "Fighting Temeraire": legend of Trafalgar*. London: Quercus.

The example was found in good shape (came with a bibliographic reference too) and a **VOTE** to accept it was called:

In favor: 8

Against: 0

Outcome: the example will appear on the CIDOC CRM v7.1 as is.

The sig reviewed the example provided by MD and LH:

The Saint Titus reliquary (E22) *P196 defines* the spacetime volume of the Saint Titus reliquary [the reliquary has been kept in the Saint Titus Church in Heraklion, Crete since 1966 and contains the skull of Saint Titus]

Discussion: The example needs more context to be fully appreciated (GH). And a reference.

DECISION: pause the vote until the example has been [updated with more context](#). (MD HW to revise the example).

DECISION:

- (i) The examples for **P174** and **P183** are accepted. The example for HMS Temeraire (**P196**) is accepted as well

- (ii) The example for the reliquary of St. Titus (**P196**) will be update and reexamined within the current sig meeting.
- (iii) **The following properties still lack examples.** Sig members are kindly asked to contribute to the discussion. Given the overlap between Issues 484 and 339, the discussion of any examples that may turn up, will be part of issue **339**. Examples from archaeology involving relative chronology would probably serve best.
 - a. **P175** starts before or with the start of (starts after or with the start of),
 - b. **P176** starts before the start of (starts after the start of),
 - c. **P182** ends before or with the start of (starts after or with the end of),
 - d. **P184** ends before or with the end of (ends after the end of),
 - e. **P185** ends before the end of (ends after the end of).
- (iv) Start a [new issue](#) on the **interpretation of periods in the CRM (settlements and administrations of the communities involved)**. MD and AK are assigned the task to do some research on the interpretation of periods.

NEW ISSUE: How do we interpret periods in the CRM

Upon discussing the example for P183 ends before the start of (issue 484), there was disagreement regarding whether a phase of a settlement should be construed as an instance of E4 Period or E7 Activity. The sig decided to start a new issue to address the debate on **how to interpret periods in the CRM (settlements and administration of communities involved)**.

HW: Research on the new issue –MD, AK.

339: References to examples of CRM text

Some properties (only 5) still lack examples and some classes and properties are showcased by fictitious examples. A summary of the said classes/properties can be found [in the spreadsheet](#). The set of the examples currently in the CRM (accepted and proposed) can be found [here](#).

DISCUSSION:

CB: to ask the sig members to review the citations found in the document and check whether they actually match the class or property they are supposed to help illustrate.

MD: has updated the spreadsheet, suggests this work should be continued.

GB: suggested that the sig editors/reviewers could be given access to the documents, in order to fix problems as soon as they spot them. Could be done through Zotero.

TV: the issue is not presented in a decidable form –we need to figure out what remains to be done for CIDOC CRM v7.1. May be best to form a small task force and work towards resolving the issue. The work would have to take into consideration other open issues concerning poorly documented/unsatisfactory examples of classes/properties.

PROPOSAL

MD: since man of the problematic examples form part of other issues that will be discussed in the 48th sig meeting, they should be resolved in their respective issues.

Once this is done, CB (HW) should update the lists above (spreadsheet and document) to reflect the current status for CIDOC CRM v7.1.

The examples and citations provided thus far will be included in the CIDOC CRM v7.1.

From then on, if someone using the CRM finds a citation that is not as it should, (s)he should immediately raise an issue through the sig, explaining what the problem is.

VOTE: MD's proposal was put to a vote

In favor: 9

Against: 0

Outcome: Motion passes

DECISION:

- i. CB (HW) should update the lists above (spreadsheet and document) to reflect the current status for CIDOC CRM v7.1.
- ii. The examples and citations provided thus far will be included in the CIDOC CRM v7.1.
- iii. From then on, if someone using the CRM finds a citation that is not as it should, (s)he should immediately raise an issue through the sig, explaining what the problem is.
- iv. Issue is closed

[404: modification of the scope-note of E81 Transformation and properties P123 resulted in \(resulted from\), P124 transformed \(was transformation of\)](#)

Background:

Scope note updates were put on e-vote. Objections were presented for the examples. New HW for the examples has been submitted (E81, P123 and P124 (**HW** by AK and ET). Sig discussed whether to approve them.

DISCUSSION:

GB: The Dominkannerkerk examples do not involve irreversible changes. They are about one and the same building that changed uses and they record different phases of the building. It would be best to use examples involving the documented reuse of spolia in their construction (like the Little Metropolis building)

MD: agrees with GB, he likes the idea of incorporating examples that illustrate the reworking of buildings. Proposed to contact Livio De Luca (**LdL**) to get a second opinion on how to mark transitions in the use (and ensuing identity) of a building.

PROPOSAL: Vote on accepting the new examples (Tut-Ankh-Amun, carbonization of the people in Pompeii) [NOT the ones related to the Dominikannerkerk], keep the example for the Venetian Loggia in Heraklion

VOTE: concerns keeping the already existing examples and introducing all the proposed ones (except for the ones about the Dominikannerkerk) for E81, P123 and P124, collectively. Any more examples that can be produced along the lines of the discussion will be discussed on [Day 3 of present sig meeting](#).

In favor: 8

Against: 0

Outcome: The examples documented in the appendix ([E81](#), [P123](#), [P124](#)) will appear in the CIDOC CRM v7.1 as they are.

Then the sig discussed if the object/building is not substantially altered, we should not be documenting the change in use as an instance of E81 Transformation. The sig added a clause that a change in the use of an object (especially for buildings) does not count as an instance of E81 Transformation, in and of itself, and decided to **discuss the examples of E81 Transformation and its properties, in the light of transformations that do not only have a physical aspect, but a functional one too.**

The discussion continued on the 3rd day ([Day 3](#))

[503: E13 Attribute Assignment \(examples\)](#)

The sig reviewed the examples for E13 Attribute Assignment, P140 assigned attribute to, P141 assigned, P177 assigned property type, E14 Condition Assessment, P34 concerned, P35 has identified [HW by TV]. Following some minor edits, the sig called a vote to accept the examples.

VOTE

In favor: 8

Against: 0

Outcome: Accept the examples. Details of changes in the [appendix](#).

DECISION: TV to check whether the property examples are consistent with the template (No of referred class appears where it should, italicized labels of properties). Accept the examples in CIDOC CRM v7.1.

Issue is closed.

[514: Revision of the examples for E54 Dimension](#)

1) The sig voted on the new example proposed for E54 Dimension [RS]

- Christie's hammer price for Vincent van Gogh's "Still Life: Vase with Fifteen Sunflowers" in London on 1987/03/30 (E97) [GBP 24.75m]

In favor: 8

Against:0

Outcome: Incorporate the example as is in the definition of E54.

2) The sig voted on amending the example re. the Battle of Issos as proposed by SdS

In favor: 9

Against:0

Outcome: Update the example as is in the definition of E54

The example changed

From (OLD)

- The duration of the time span of the Battle of Issos [333 B.C.E.]

To (NEW)

- The duration of the time span of the Battle of Issos/Issus on 15th November 333 B.C.E. [less than 12 hours]

DECISION: Update the CIDOC CRM v7.1 text accordingly,

Issue is closed.

382 where to stop documenting provenance

Open end discussion to establish whether the issue needs be further pursued or dropped. A text has been put together by MD and CM that serves as a guideline to the end user on where and how to include provenance information as regards the statements that are held in the knowledge base.

PROPOSAL:

The text to be kept as a starting point and be revised accordingly. It should be cross-checked with the RDF implementation document. Add diagrams based on a toy-example to demonstrate when provenance statements are necessary, the knowledge of the maintainer and how provenance statements are chained. Maybe incorporate ULAN entries.

RS: example of a ULAN entry in CIDOC-CRM <https://data.getty.edu/vocab/ulan/500027372>

NEXT STEPS:

- (1) Talk with the Getty about getting examples from ULAN,
- (2) create named graphs (either in x3ml or by hand –**HW**: ML; consult MF, NC)
- (3) put together a task force to work on the text (add examples etc.):
 - a. FORTH: MD
 - b. Takin: GB
 - c. Getty: RS/GB
 - d. CHIN: PM
 - e. SARI: ML, NC
 - f. Uni Köln: OE (can support in terms of critique examples, chains of provenance)
- (4) Revisit the issue in the next sig meeting

513: Replacement of the fictitious examples for P198

Postponed for **Day 3** –pending HW by RS.

288: Issue about P81 and P82 usage

Following the parallel editing of two texts that got everyone confused regarding what the last updated version was, CB was assigned to compare the two texts for differences. Issue paused, will be discussed again over the 48th sig meeting. Details [here](#).

417: begin_of_the_begin /end_of_the_end is excluded from time range?

The sig reviewed MDs HW –statements in the guidelines regarding how to convert time spans given in days or years to xsd:dateTime values when implementing P81a/b and P82a/b.

RS suggested that it is possible to document smaller time fragments than seconds.

AK: in none of the historical archives she has examined were there any xsd:dateTime values documented. The data documented longer periods and located events/activities within them. If something is documented as having taken place/ produced and destroyed/ (...) somewhere within the 18th century, it makes no sense for the database handling the relevant information to reason with respect to the last second of December 31 1799.

A vote was called on adding the statements proposed by MD in the P81a/b and P82a/b implementation document, for each property respectively;

VOTE:

In favor: 6

Against: 0

Outcome: The statements for rounding the range of the time spans of P81a/b and P82a/b found below will make it into the guidelines.

P81a/b

If a value for “P81a_end_of_the_begin” is given with a precision less than that of xsd:dateTime (i.e. seconds), such as in days or years, the implementation should “round it up” to the last instant of this time expression, e.g. 1971 = Dec 31 1971 23:59:59. Respectively, for “P81b_begin_of_the_end” the implementation should “round it down”, e.g. 1971 = Jan 1 1971 00:00:00.

P82a/b

If a value for “P82a_begin_of_the_begin” is given with a precision less than that of xsd:dateTime (i.e. seconds), such as in days or years, the implementation should “round it down” to the first instant of this time expression, e.g. 1971 = Jan 1 1971 00:00:00. Respectively, for “P82b_end_of_the_end” the implementation should “round it up”, e.g. 1971 = Dec 31 1971 23:59:59.

Issue is closed

501: examples for P81 and P82

The sig reviewed the examples for the integration of (i) non-contradictory minimal extents and (ii) non-contradictory maximal extents to illustrate P81 & P82, respectively. A vote was called on whether to accept them.

VOTE:

In favor: 8

Against: 0

Outcome: the examples are accepted. Details in the [appendix](#). REFERENCES NEEDED (but not a priority)

Issue is closed

DAY 2

Modelling of the Paintings by CIDOC CRM

[Presentation](#) by Maliheh Dorkosh (MDo)

Discussion:

MD: asked about the possibility of sharing mappings to the CIDOC CRM with the sig, as they probably present solutions to problems that other researchers/institutions have come across. The same goes for extensions. He also asked MDo for feedback regarding the main text of CIDOC CRM –what topics need to be expanded.

GB: in modelling information on paintings and miniatures, (a) what are the most difficult things to represent, and (b) are you considering to expand her model to integrate other datasets and making it more generally applicable –to Iranian Art, for instance?

TV: What is it that the Qoqnu software does? Is it for publishing data online?

MDo: Learning to use the CIDOC CRM can take time. Finding good resources to learn CIDOC CRM are scarce. She used CIDOC CRM v6.2.1 in her research.

Qoqnu supports CIDOC-CRM (in its official ISO version 5.0.4) it is used for implementing and representing the relational database of the museum in CIDOC CRM

She drew a graph incorporating every CIDOC class and property. That she imported to Qoqnu. but the Qoqnu database is implemented in the official ISO version (5.4).

In general, there were properties in schema.org that were not used in the Malek Museum’s databases. She had to add them to the concept that matched CIDOC-CRM.

[Implementation of CIDOC-CRM for the Domain of Iranian Archaeology. Presenting CRM-based database Qoqnu for excavated objects from “Veshnavah, Iran” Presentation](#) by Massoomeh Niknia (MN).

Discussion:

GB: wanted to know about translations. In the Qoqnu interface the classes are expressed in English, what was the process of translating the CIDOC-CRM into Persian like? The release of the upcoming version will inevitably launch a large-scale translation project and the sig could benefit from the experience of the Iranian community of CIDOC-CRM users.

MN: The project of translating the CRM in Persian was undertaken by a group of scholars (MDo included). The Qoqnu database itself is based on CIDOC CRM.

She registered the lack of terms in Persian as a major challenge for the translation project, meaning that there is no one-to-one correspondence between the English and Farsi terms. Some concepts that are considered common/shared background knowledge and are silently assumed by the official (English) CIDOC CRM version are hard to grasp, explain and implement in non-English speaking communities.

During the translation project, they were aided by the Academy of Persian Language and Literature, who helped coin new words to match the concepts found in the CRM. She wished there to be a closer collaboration with the sig from now on in terms of translating CIDOC CRM concepts in Farsi.

GB: It is an issue in its own right to talk about how the sig can facilitate expressing the CIDOC CRM concepts –especially the top-level concepts that are used everywhere in the model and appear across

different language speaking communities. The more translation there are, the more interesting the results of integration of non-English data that are accessible nonetheless.

MD: There is a table of translated CRM concepts on the website that should be constantly updated, it would be great if MN or MDu or some other co-worker can add the translations in Farsi. The CRM is not innately English, the concepts are not language-specific. The scope notes stand as the definitions of the concepts, the labels are just mnemonical devices. Maybe we need more verbose scope notes to render the exact meaning of the concepts at hand, either by providing synonyms or closely related terms for the ones we use. The collaboration and feedback would be beneficial for all.

Did you consider any mapping software to do the data entry –f.i. the X3ML toolkit?

MN: It was incompatible with Farsi, so no. Besides her corpus was small. They extracted some data, created xml documents based on the excavation reports and made a graph out of it. The graph is not very informative for shortage of data.

[Towards the Ontological Analysis and Modularization of the CRM \(v.6.2.1\) Presentation](#) by Emilio M. Sanfilippo (ES).

Discussion:

GB: The observation about E72 Legal Object is very interesting. It is a non-neutral class expressing a particular social-cultural phenomenon. It's fine for representing data that belongs to western museums, but once you extend it to the people for the benefit of whom the objects have been displayed in museums, then viewing them as legal objects does not make too much sense.

MD: the larger part of what the presentation proposed as improvement/logical clarifications has been extensively discussed and is the outcome of an active decision. The points ES raised are very interesting for ontology modelling and its relationship to reality; since there is not room for discussion in the remainder of the session, he proposes that they would like to have a side meeting to discuss them further. Some examples follow:

- DOLCE introduces these negatively defined concepts. The position of the sig regarding this practice is that it violates the open-world assumption. Negating something can only be decidable IFF the set is finite; for non-finite sets, defining the complement of a set yields something that lacks properties.
- We do not model the notion "former". The OR in properties of the form *Pxxx has current or former SOMETHING*, is not construed as a disjunction, but rather as a deliberate generalization, where we formulate one component that we can identify, rather than taking the complement of current. If you want to define "former", you can do so, but not by assuming that "it's the opposite of current" –it should have a separate identity. Then "current or former" would be a generalization over the two independently defined concepts –not a disjunction thereof.

ES: in what concerns making use of set-theoretic complements, it is a go-to practice when one wants to make a class disjoint from everything else. If you want to make statements about all animals except for humans, then you might want to use that. He has not considered the issue of non-monotonicity, but by defining a universe that does not comprise any humans at all, then you don't need a finite set to ascribe properties to the individuals in it.

CEO: would like to participate in the discussion.

[Recording Absence & Negative Properties Presentation](#) by Athanasios Velios (TV)

Discussion:

OE: representing absence with typed properties and negative typed properties fits how he understands the non-presence of geographical features: a statement of the sort “there is no farm at place x” is not about a farm that existed in the past and has now been abandoned/demolished. Rather, it is a statement about a type of edifice that was never instantiated.

MD: Negative properties are in conflict with respect to the open world assumption. A possibility would be to see a negative statement as imposing a small closure in an otherwise open world. Meaning that the object that the negation is about (domain) has been completely investigated. He would be interested in formally representing that, in an unambiguous fashion. Maybe ES would like to contribute.

ES: independently of the open world assumption, there is a distinction between logically modelling this – like inserting a negation operator where it is needed –and assuming the existence of an object has negative properties –like saying that *x is NOT Italian*. From the presentation, what seems to be of interest is the logical negation.

OE: In his examples the issue is clearly about things that do not exist, rather than (negative) properties of existing things. In the book history example, on the other hand, things are not just as straightforward because there is an actual physical object present (the book) and it has some features. The negated features clearly don’t exist, but you can render it in a different form, i.e. not negate the existence of an object or feature, but make the negation part of an argument on a specific form.

This is also a question about language. In many cases the “non” is part of non-negated statements. The description “non-fictional” is applied to a certain branch of literature, and the negation in the label is a historical-etymological residue that no longer forms part of its content. So, you have to maintain the distinction in the use of “non”, where it purports a negation from the cases where its negative content has been filtered out of the meaning of the word.

MD: The logical formulation for ***does NOT bare feature of type*** would be, that for all features of a given book, none is of type x? So this quantification would represent a closed world.

TV: No, it’s more like “given an object x, there is no feature y on x, such that y has type z” (see the axiom by CM $E22(x) \wedge P2(y, \text{“tooled decoration”}) \rightarrow \neg P56(x,y)$).

GB: to reduce the ambiguity, i.e. that it is about a specific instance of an object that we’re talking about rather than all objects of type x, it the E22 should have an individual constant, and not an individual variable.

MD: To make a negative statement means that there has been a complete observation. This must always be made explicit.

AK: what happens if a thing gets its identity from a negative property? Samples (biology) come to mind – negative for COVID-19 for instance.

OE: it should match the geospatial data he had to model: in a densely populated area, a concept “farms in the area” describes the existence or non-existence of farms. There is no way to describe at a great detail all living beings in the area, or all buildings in the area, but one can be sure on the existence of farms or not. If there are 4 farms in an area, they form a closed world.

TV: is it reasonable to proceed with the typed properties and the negative typed properties and produce an rdf file? It would mean that scope notes would need to be written, examples to be supplied etc. We could carry on in this line of work and resent the outcome at the next sig.

MD: we should make an issue of that and produce guidelines. Present the properties as an extension to the CRM and provide scope notes as well.

HW: TV will start a new issue, and he and SdS will continue working on the negative properties, and on the properties of the CRM that should be generalized to typed properties.

509: Modifying Art Objects

MD presented HW on how to treat modified art objects.

ES: in DOLCE you can only ascribe temporal parts to temporal entities –you can talk about the beginning of a battle for instance/someone’s life etc. There are approaches that model relatively stable phases/stages of physical entities in the course of time –like childhood, f.i. –but he cannot give an outline off the top of his head. There should possibly be some sort of constraints, like the same amount of matter should be present both objects –that would give rise to a continuity.

MD: the amount of matter may be completely lost. For a living body it would amount to the continuity of the physical coherence of the body parts. The etching blades of Rembrand are well documented, they form good examples. If we model this correctly, we have solved the problem.

ML: would like to be part of this discussion. How do we proceed? Should we use OntoClean?

MD: discuss on the desired output of this collaboration in a side meeting, this way we could prepare some concrete HW. The research question relates to the ontological assumptions about the relationship to reality. It translates into what would be the underlying justification for the different views presented.

Share with ES the document Modelling Principles.

Applying OntoClean to the CRM would be very interesting

ES: the scope of CRM is huge, we should contain this to one particular aspect. We should pick one.

MD: the definition of complements is a research question that he is personally invested in, because it’s strictly forbidden in the CRM.

ES: start a discussion group within the sig to discuss the different phases of a painting etc.

486: Labels of O19 and O21

AK presented the issue and proposed solution. The proposal was to relabel O19 and O21 to reflect that they link from instances of S19 Encounter Event. Originally the properties were known as:

- a) O19 has found object (was object found by)
- b) O21 has found at (witnessed)

PROPOSAL: Change labels

- c) FROM O19 has found object (was object found by) TO: O19 encountered object (was object encountered at)
- d) FROM O21 has found at (witnessed) TO: O21 encountered at (witnessed encounter)

DISCUSSION:

Is the labelling inconsistency btw the name of the property and the kind of activity described in the scope note a problem? Do we change the description of the activity in the scope note to reflect that it is of an “encountering type”?

RS and MD would like to see that happen.

GB: argued against editing the scope note at this point, because even though finding something and encountering something may be different things in an archaeological context, changing all expressions in the scope notes to a variant of “encounter” makes the scope notes tautological. Instead, just change the labels, and start a new issue to discuss any updates on the scope note.

VOTE to decide on renaming O19 and O21

In favor: 10

Against: 0

Outcome: O19, O21 will be relabelled to *encountered object* (was object encountered at) and *encountered at* (witnessed encounter), respectively.

DECISION: Motion passes, a [new issue](#) will start to reflect on changing the scope notes to take into account appropriate use of verbs: “encountered” and “found”.

Issue is closed

[NEW ISSUE: reformulate the scope notes of O19, O21](#)

Reformulate the scope notes of O19, O21 to reflect the distinction between an encounter event and a finding event, when necessary

HW: MD, RS

[448 O17 isA O18](#)

AK presented the issue. According to a decision on the 45th sig meeting, **O17 generated** (was generated by) [D: S17 Physical Genesis, R: E18 Physical Thing] should be declared a subproperty of **O18 altered** (was altered by) [D: S18 Alteration, R: E18 Physical Object]. S17 Physical Genesis isA S18 Alteration, so it makes sense to go forward with the proposal.

DISCUSSION:

There should be a graphics representation that illustrates the relation between properties and linked classes for CRMsci.

GH: a similar decision was implemented for CRMarchaeo, it forms a precedent.

MD: We should start a new issue re. the introduction section of CRMsci. It should be updated –i.e. it should give an outline of the basic concepts of the model and be supplemented with graphs. Maybe some of the graphs that are needed are in the CRMsci tutorial.

CB: the CRMsci tutorial has graphs, but it has not been updated since 2014. It is can be found [here](#)

MD: slide 16 of the CRMsci tutorial is relevant for representing the O17 isA O18 relation. Maybe update some of the diagrams incorporate them in the introduction section of CRMsci.

VOTE: O17 isA O18?

Yes: 11

No: 0

Outcome: accept proposed change.

Issue is closed

NEW ISSUE: [add graphics to the CRMsci definition](#)

Update diagrams to make sure that they are compatible with v1.2.8; incorporate them in the introduction section of CRMsci. It needs to be checked -text might end up changing a bit.

HW; AK & CB to do the update.

[388: reference to the measurement of the position of things.](#)

Background: difficult to define what entities can be measured. A measuring activity is understood as involving signals. Be it endpoints on some measuring rod; or in the case of events, their beginning and end points on some time scale. In the case of measuring the position, is to be placing something in absolute space. But any measuring instrument we have for measuring in absolute space produces approximations –GPS signals are relative to some reference system and reference points. So, a position measurement is a directed distance btw Greenwich f.i. and the point we’re interested in. But talking about position measurements as directed distances is very inconvenient. We need to talk about position measurements that produce geometric place expressions as a result.

The question is:

- a) Is position measurement needed?
- b) If yes, then how do we relate it to the measurement of other dimensions?

Discussion:

GB: real world dimensions of these position measurements? What would it be? And does it only work with GPS signal or could it be used in a measurement using a laser device in a piece of artwork?

GH: in archaeology, one would be measuring on the spot, using a local reference system. What is needed is to match the local reference system to add the position measurement.

MD: if we’re talking about position measurement applied to paintings, it probably falls into the same pattern. We’d have to define some sort of coordinate system for the painting. In CRMbase this would translate into an E53 Place that has a reference object –the painting. The place would be P157 at rest

relevant to: E15 Physical Thing (the canvas) and then it would use an E94 Space Primitive, which, in its turn, would encode how the coordinate system in which the position is given applies to the boundaries and the edges of the canvas.

Since generalizing to events from GPS signals is not self-explanatory (see. Oxx3 covered event: E4 Period; Oxx5 fell within event: E4 Period), there is a need for examples to help illustrate: observation of some species, measuring the position of an earthquake.

MD: if we take a position measurement, it's just coordinates. We need to assign a position measurement to an encountered object (+place) or an encounter/other event (+place it occurred at). An archaeological excavation at an instance of E53 Place is documented by a GPS signal obtained at said place. Obtaining a position measurement is an indication of where the event of measuring occurred (also indicates the location of an encountered object).

Finding an object in a layer, and has the coordinate system at hand, means that you can say that the object was found at place x. Oxx2 covered thing would apply in this case. If the place is somewhere within this object, then Oxx4 fell within thing: E18 Physical Thing would be used to document the instance of the place of the position measurement.

GH: Oxx2 covered thing and Oxx4 fell within thing both have E18 Physical Thing as range? (YES).

AK: the original example involved GPS coordinates linked to the place of an encounter event from a fishing activity in the ocean, and at the same time, this was a sampling activity.

TV: there was a discussion on the sig list a while ago, initiated by RS –regarding the nature of E54 Dimensions and whether places have dimensions. Is this relevant to the present issue? Where did that discussion lead to?

RS: We needed to look at measurement and dimension, also in relation to discussions that took place in the context of issues: 229, 293, 307. What seems related to this particular issue is that the range of P31 measured is E1 CRM Entity, which allows the measurement of instances of E53 Places. On the other hand, only E70 Things can have dimensions. While one can measure a place, it's not possible to assign it a dimension.

MD: it is not a place that is measured, but something that occupies space (has a place). We measure things, i.e. features that are at some place. This means that we can only measure phenomenal places (space occupied by things) and not declarative ones. Dimensions can of course be determined by computations –other things than measurements –but things that have a dimension are more than the things that can be measured.

PROPOSAL:

To introduce a measurement event class that allows to give a provenance of a dimension that is attributed to a thing. We have not heretofore had a class that gives a provenance to why a place is attributed to an event or an object. The motivation is that so far we have not had the means to express where the observation of a thing/event took place.

GB: Since this is CRMsci, why not set the range of Oxx2 covered thing and Oxx4 fell within thing to S15 Observable Entity?

MD: the notion of Observable Entity has yet to be adequately defined. What is behind the capability of measuring, in a general sense of physics, is to be able to register signals. Such signals relate to observable entities –but how to make the connection between the signals and the observable entities is not yet clear.

GH: attach the means of measurement, which is very important to establish the precision in the measurements.

Moving forward: Do we accept the introduction of a class for position measurement in CRMsci? And if yes, it needs scope notes and examples. To begin with we need examples. If it's just GPS it would mean that we should only use CRMgeo. If it's not to be contained in CRMgeo, we would need more data from other domains.

AK: all the examples thus far come from archaeological data.

MD: proposed to accept the introduction of **Sxx Position Measurement** and properties linking from it, and then go on and find examples. Examples should include:

- a) Position measurement on a painting (specify the coordinate system on a painting)
- b) Traditional setting up coordinates/measuring 'triangles' to reference points
- c) Fishing
- d) GPS

GH: No need to repeat defining a coordinate system in the CRM, one can always use GeoSPARQL or GML instead.

MD: should a relative position on a painting be described through GML?

GH: a text re. where to put the point of the reference system must be provided. If there is need to define the reference system in a more formal way, there's always GML. The text should be an additional property of the position measurement rather than Space Primitive.

GB: proposed to carry on working on the issue (with examples etc) and then move on to accept the class and properties (scope notes and examples) at a later stage.

MD: insisted on accepting the class and the properties as given and then elaborate the details of how the reference system should be defined.

TV: hesitant, he finds it hard to come up with real examples on position measurement on paintings off the top of his head. Would like to see some concrete examples before voting on introducing a class and properties in the CRM.

GB: does not wish to introduce a set of class and properties without having gone through a concrete set of examples OR scope notes. Proposes that we only decide on proceeding with it, but for the next sig meeting.

CB: the scope note for the class has been shared through the sig list a long time ago, and it keeps getting postponed. We should take a look and decide what to do with it at some point.

MD: if we want this class, then we move on to producing scope notes. Cause there are no scope notes for the properties.

TV: since we've said we'll go on with this, it means that we'll have to review the scope note of the Sxx Position Measurement class and provide scope notes for the properties linking from it. It will involve doing some HW. But things are ultimately set in motion.

HW: review the scope note for the class, produce scope note for the properties, come up with examples for both the class and its properties from multiple fields/domains/ use cases to show its utility and where to put the determination of the coordinate system.

HW Assigned to MD, GH, TV, plus AK & CB –with data from Sarris' system)

332 Properties of S10 Material Substantial

TV presented his HW: reformulation of the scope- note for O27 split.

DISCUSSION:

MD: it's a property that only applies to homogeneous samples, i.e., cases where sub-samples retain all the characteristic properties of the original sample they were removed from. Would prefer a more complex reasoning, whereby the split sample only shares a subset of the characteristic properties exhibited by the original one. Sampling involves looking for DNA. If you extract a tooth from a skeleton that's sampling. And if you take a sub-sample from that tooth (where you can get the most DNA from) that's splitting off from the original sample. The original sample is not homogeneous. So, the part that has the most DNA to work with (i.e. the split sample) exhibits a subset of the characteristic properties compared to the tooth (i.e. the original sample).

TV: that particular case represents an instance of two subsequent sampling activities.

MD: Maybe we could disambiguate by adding a comment, that if we sample from an already obtained sample and if the original sample is not homogeneous, then this would fall into the definition of O5 removed.

GB: if this property talks about the sample that has been produced by the sampling just in case you sample from a sample, then doesn't it need a paired property like Oxx split from: S13 Sample that is a subproperty of O3 sampled from: S10 Material Substantial? And wouldn't that require the introduction of another class like Sxx Splitting?

You can only split off a sample, which is a subproperty of O5 removed and creates a sample.

TV: like a sample taking that results into the new sample. It's still an activity of sampling. One can always use O3 sampled from: S10 Material Substantial.

GB: a new class is needed, because we have the hierarchical relation S2 Sample Taking –O27 split from: S13 Sample isA S2 Sample Taking –O5 removed: S13 Sample, according to which a subproperty does not restrict the scope of its superproperty in any respect. That goes against our practices. If we like this property, then we should restrict it somehow. By adding a new class (sample splitting or other).

PROPOSAL:

- Add a class: Sxx Sample Splitting isA S2 Sample Taking,

- O27 split [D:Sxx Sample Splitting, R: S13 Sample] of O5 removed [D: S2 Sample Taking, R: S13 Sample]

DISCUSSION

RS: Do we really need a new property now that this has turned into a class? If you have a sample splitting activity that is a subclass of sample taking, doesn't everything that applies to sample taking apply in the case of sample splitting as well?

GB: in favor of two new properties (mirroring O5 removed and O3 sampled from), to differentiate this process from sample taking (as it presupposes the existence of a homogeneous sample wrt. a set of properties, from which to sample).

MD: this corresponds to a set of very commonly used lab procedures. Taking homogeneous samples or rendering samples homogeneous. An example of the process would be the urine sample that the cyclist, Armstrong, had to give –which was subsequently divided in X number of subsamples to be examined by different labs.

RS: the question is, would the range of the property Oxx split from be set to S13 Sample, or would it be considered an instance of S10 Material Substantial, still? Can we split something that is not a sample?

GB: Assuming we keep the property, this means that we need to introduce a new class as well, because we cannot declare two properties with the same domain and range, one a subproperty of the other. It does not entail that a new property for the *taken-from* aspect is needed, because you may just be splitting something that's homogeneous and not something that was prepared as a sample –i.e., to be homogeneous.

Re. the example: example was good and had nice references.

HW to TV to update as discussed.

HW to MD to add an example for the analysis of Armstrong's urine.

DECISION: implement the HW stated below:

TV to edit the scope note of O27 split as discussed (change the domain), provide scope note for Sxx Sample Splitting (?), and update the example accordingly.

MD to provide an example for the subsampling of Armstrong's urine.

[484: 7.0 preparation –missing examples](#)

The sig reviewed the updated example for P196 defines (is defined by) [D: E18 Physical Thing, R: E92 Spacetime Volume] (HW: LH), which incorporated previous feedback, did some editorial changes and voted on accepting it.

- The Saint Titus reliquary (E22) *defines* the Spacetime Volume of the Saint Titus reliquary (E92) [the reliquary has been produced by the workshop of the Vogiatzis brothers located at Monastiraki, Athens, in 1966 as container for the skull of Saint Titus, which was placed into it at that time and has since then continued to fall within the container's spacetime volume. The reliquary with the skull has been kept in the Saint Titus Church in Heraklion, Crete since 1966] (Fisher&Garvey 2010)

VOTE to accept the reformulated example:

In favor: 10

Against: 0

Outcome: example accepted.

Pending –to be revisited in [Day 3](#): additional examples for E9 Move and its properties (**HW** by MD).

DAY 3

404: modification of the scope-note of E81 Transformation and properties P123 resulted in (resulted from), P124 transformed (was transformation of) –continuation

Following the discussion on how a change in the intended use of an object can motivate transformations of the object itself, MD proposed to reformulate the scope note of E81 Transformation. The idea is that the scope note should reflect that a change in use of an object should only be documented through E81 Transformation insofar as there is physical evidence of substantial material changes. If the change is just a matter of how one and the same object is used, the documentation can go through E7 Activity and further typing.

VOTE: a vote was called in support of MDs proposal.

In favor: 7

Against: 0

Outcome: The clause was added, see [appendix](#) for the amendments.

Furthermore, the sig reviewed the new example (HW by MD) on the Hephaisteion and its transformation into a Christian Church, which helped preserve it. It was proposed that the Dominikannerkerk examples should be abandoned for E81 and its properties (P123, P124).

VOTE: to abandon the Dominikannerkerk examples (from E81, P123, P124) and to add the example about Hephaisteion in the definition of E81.

In favor: 7

Against: 0

Outcome: The example is added in the definition of E81

DECISION:

- i. Add [clause](#) making the implementation of substantial material changes on an object a prerequisite for an action to count as an instance of E81 (i.e., a transformation is not a matter of changing the use of an object).
- ii. Add new example ([Hephaisteion](#)) in the definition of E81.
- iii. Use it as a template for examples of P123, P124.
- iv. **Issue closed**

484: 7.0 preparation –missing examples

The examples for E9 Move and its properties were discussed again. MD suggested that we shouldn't be talking about THE Tutankhamun Exhibition, because there have been more than one such events. That said, the packing and moving of the exhibitions mentioned in the examples might not come with

references, but are restricted by actual dates between the end of one exhibition and the beginning of the next. The actual move must fall between the two dates.

E9 Move:

The movement of the exhibition “Tutankhamun: Treasures of the Golden Pharaoh” between Sept 15 and Nov 2 2019

P26 moved to:

The movement of the exhibition “Tutankhamun: Treasures of the Golden Pharaoh” between Sept 15 and Nov 2 2019 (E9) *moved to* the Saatchi Gallery London (E53)

P27 moved from:

The movement of the exhibition “Tutankhamun: Treasures of the Golden Pharaoh” between Sept 15 and Nov 2 2019 (E9) *moved from* Paris, Grande Halle de la Villette (E53)

DISCUSSION:

Maybe there is a catalog of the exhibition that could be used to document the example.

VOTE: A vote was called on whether to accept these examples for E9 and P26, P27.

In favor: 8

Against: none

Decision: The examples will be added to the definition of E9, P26, and P27, respectively.

[288: Issue about P81 and P82 usage](#)

Continued from DAY_1:

CB presented a pairwise [comparison](#) of the “Guidelines on how to use P81 and P82” found under “Best Practices”, and the new version produced by MD. The differences were minor and involved

- 1) Adding the citations where necessary
- 2) Moving the paragraph about negative time intervals under P81a/b
- 3) Different phrasing when to avoid documenting the instance of E61 Time Primitive corresponding to the *end-of-the-end* of the relevant time-span: instead of expressing a possibility, it was changed to express necessity.
- 4) Deleting the note re. the other possible ways that one could come up with to deal with imprecision and temporal reasoning.

In total, the new version that MD produced is more up to date than the one implementing the relevant decision of the 42nd sig meeting. The sig voted on whether to accept the changes proposed by MD.

VOTE: to accept the changes [1 through 4, above], change the date of the document [set it to current: 23 October 2020], incorporate it as an appendix to the document “Implementing the CIDOC Conceptual Reference Model in RDF”, published on the CIDOC CRM site under Best Practices.

In favor: 7

Against: 0

Outcome: The proposal passes. The updated text (citations, changes) can be found [here](#). The text is to appear as an appendix to the document “Implementing the CIDOC Conceptual Reference Model in RDF”, published on the CIDOC CRM site under Best Practices –it is to substitute the current version of the text.

CB presented a pairwise [comparison](#) of the document labelled “Implementing the CIDOC Conceptual Reference Model in RDF” in its google doc version, to the version published under Best Practices in the CIDOC CRM site. This document has been developed under the issue 443. There is one difference that needs to be addressed in the sig, namely the addition of following chunk of text in the section concerning linking to authority files (chapter: CIDOC CRM and other frameworks).

“It is also incompatible to use skos:exactMatch to link from CRM instances to authorities such as VIAF, ULAN and TGN. Authorities often define places and people as skos:Concept for classification in their discourses and assign a URI for each instance of skos:Concept. These URIs are instances of E41 Appellation. Therefore, it is recommended that instances of places and people should link to authorities with the property P1_is_identified_by.”

DISCUSSION:

TV mentioned that communities using the crm are not particularly happy with this solution (especially in the context of LinkedArt, this has come up a lot). The problem would be that P1 is identified by, will always link to a label of sorts, whereas the common practice is to reason about the things the URIs stand for, not their labels.

It was agreed that since any URI that stands for a thing in a knowledge base constitutes simultaneously an appellation for the thing, the text should be included despite implementers not liking it. And it should be explained more, if necessary.

VOTE: The sig was called to vote whether

- (a) to accept the addition of this text to the document,
- (b) to substitute the annex on how to use P81a/b and P82a/b with the one discussed earlier,
- (c) change the date of the text to the current (October, 23 2020) and set its version to **1.1**,
- (d) close the google doc,
- (e) and close the issue 288 AND [issue 443](#)

In favor: 7

Against: 0

Outcome: Motion passes. The text in its current version (1.1) can be found [here](#). It is to appear in its updated version under Best practices.

Issue closed

[443: Implementing the CIDOC Conceptual Reference Model in RDF](#)

Upon discussing issue 288, the sig resolved to close issue 443 as well, seeing as the document is now complete.

496 Types for P2 has type

Background:

In the scope notes of CRM classes/properties, we implicitly refer to types. Which means that the specializations allowed should not be just any term, but a narrower term of what is supported by the semantics of the class.

MD presented his HW (a list of classes invoking types for further specialization, deprecated classes that did just that, or properties linking to types). The question is should we make recommendations specifying the minimal vocabulary to be used in each case?

Examples include:

(a) Classes:

E3 Condition State (f.i. type “wrecked”), E10 Transfer of Custody (f.i. “legal responsibility” vs. “actual physical possession”, vs. “legal responsibility AND actual physical possession”), E15 Identifier Assignment (f.i. “preferred identifier assignment”), E4 Period (f.i. “jurisdictional area” vs. “administrative system”, etc... See also [NEW ISSUE: How do we interpret periods in the CRM](#)), deprecated classes (f.i. former specializations of E41 Appellation could serve as a type recommendation).

(b) **Properties:** measurement: f.i. P33, P125, P16 the range of which can be extended by P2 has type: E55 Type. Note the possibility of a competing interpretation of P32 used general technique: E55 Type vs. P33 used specific technique: E29 Design or Procedure –P2 has type: E55 Type.), .1 properties: f.i. P137.1 *in the taxonomic role* (“prototypical” vs. “archetypical”, vs. “lectotype), pointing to E55 Type: f.i. P101 had as a general use: E55 Type.

DISCUSSION:

TV: push these types in BBT

MD: the BBT could take up some of the types mentioned above, but there is a difference between that and imposing all necessary types stemming from the CRM to the BBT. It would mean that the BBT becomes an official recommendation for CIDOC CRM. What he proposed instead is the formulation of some minimal vocabularies. People can use skos relations to link to external vocabularies.

GB: concerned that this would entail us having to maintain another standard along with CIDOC CRM. It is possible that the data producers might find it even harder to maintain compatibility with the minimal types vocab.

MD: Defining a minimal vocabulary doesn't have to compete with practices of data producers. If Linked Art for instance have produced such minimal requirements for their applications then we could possibly borrow that.

PROPOSAL: we need to decide if the issue is important enough to be pursued; if yes, then assign HW to sig members –interact with Linked Art and other communities using the CRM, to formulate the minimal requirements for restricting the appropriate types. Call a vote on this proposal:

VOTE:

In favor: 8

Against: 0

Outcome: The issue will be pursued further.

HW: GB communicate with RS / Linked Art and point to the direction of what has been decided so far. TV happy to contribute, MD too.

495 backwards incompatibility problems

Background:

MD presented the status of deprecated classes and properties (for version 7.0 and forth).

PROPOSAL:

Regarding the set of deprecated classes, there should be a mapping demonstrating the full paths to express data using deprecated classes [f.i. E38 Image = E36 Visual Item -P2 has type: E55 Type (image), class and vocabulary necessary to express that something is an image now that we don't have class E38 to go to].

Regarding the set of deprecated properties: It's a more complex enterprise. The fact is captured by the additional guideline expressed in the extra column. There are implementation issues as well, not just updated paths. For instance, deprecated properties P83 had at least duration and P84 had at most duration are rendered through P191 had duration with an adequate formulation of a lower and upper value limit set on P90 has value: P90a_has_lower_value_limit and P90b_has_upper_value_limit, respectively.

And a list of reduced ranges should also be included. The list of reduced ranges should be included in CIDOC CRM v7.1 (the output of the 48th sig meeting), but it should go back up to the last official version (v5.0.4).

DISCUSSION:

GB: is interested in following up with this issue, because the Getty are going to migrate their data once v7.1 is produced. He wanted to know if there are other institutions that are willing to migrate their data to v7.1, and if yes, whether they will be using v7.1 to integrate only new data, or if they would want to migrate old data as well.

MF: it's not all too easy to answer. When you change the semantics of a property then it's not a given that old data instances structured by different semantics and allowing specific implications can be automatically interpreted by the new semantics. Replacing P58 has section definition by P1 is identified by, is pretty straightforward and easy to implement. Rendering P83 and P84 through complex structures on the other hand, will be hard to implement. What they do, is make a domain ontology based on CIDOC CRM and reintroduce everything that was abolished. This document (MD's HW) should be enough to create migration paths.

MD: would still like to provide explicit migration instructions. But after CIDOC CRM v7.1 is released, because the guidelines provided thus far (and especially once it has incorporated the exhaustive list of deprecated ranges) will suffice for creating migration paths.

A **VOTE** was called on whether to continue working on explicit migration instructions AFTER the release of CIDOC CRM v7.1.

In favor: 11

Against: 0

Outcome: work on this issue will continue

HW: MF, MD, CEO, GB

506 change the scope note for E11 Modification

TV presented his HW (update the scope note of E11 Modification to include instances where an action to modify an object took place, but the desired modification result did not ensue).

DISCUSSION:

GB: Despite previous decision and all, the instance of a modification of an object that ended up not modifying the object still strikes him as a contradiction.

MD: liked the addition, but wanted to make it clear that it was a seeming contradiction –not a real one. Any such action would leave some forensic traces, doesn't matter if it was 100% successful in bringing about the desired result. But there is always evidence of an action that counts as an instance of modification.

There was some editing –to disambiguate.

GB: if this is the marginal case, shouldn't it be moved further down in the scope note? Like not make it the first thing the reader encounters.

VOTE on accepting the new scope note, edits included.

In favor: 6

Against: 0

Output: new scope note accepted. Details in the [appendix](#).

Issue Closed

500: Revise examples for E33 Linguistic Object

The sig reviewed the example proposed by CEO (HW). It is an example of real dialog documenting a local Norwegian dialect that was recorded in 1958. It has references as well. He can find other examples from actual dialectal data (Zimbabwe), but they will be in the same spirit.

The example is not of the written language, but of spoken language –which is very important if we want to capture that E33 Linguistic Object can be instantiated by spoken texts, not just written ones. He could find the transcription thereof, but it would be much harder to locate, because it was part of a different project.

For more exotic examples, we could document the recording of a theatrical performance in sign-language, but it's not necessary to do so immediately (not for v7.1 at least). We could add the examples later on.

MD: in terms of "missing citations". It is of the examples that we do not need to provide citations for (archival data).

CEO: the example is taken from a database that the University of Oslo had created. It was then moved to the university library at the University of Bergen. They can provide the physical copy, but there is no point in adding detailed citations (phone number of the University Library at Bergen etc.).

PROPOSAL:

Example:

- The free dialog in the local dialect recorded in 1958, Telemark, Norway stored on tape or.7-89.s1 (00.15:46-00:34), The Language Collection at the University Library in Bergen, Norway (as by 2020)

VOTE: to accept the proposed example

In favor: 6

Against: 0

Outcome: the example is accepted.

HW: MR will be looking for other examples from the BNF. However, the release of CIDOC CRM v7.1 is not impeded by lack of more examples.

Issue still open.

[469: A phrase of every property of every extension ¹](#)

CEO presented his HW (to establish the hierarchical relations among properties defined in the CRM-extensions and their superproperties in CRMbase). He has done that for all models, the output of this work can be found in this spreadsheet. It can be useful to determine a top-level ontology for all CRM classes and properties (for all CRM-family models). It shows which properties of CRMbase have subproperties in other models.

A more useful application is to keep track of how changes in the CRMbase (or some other family model) affect the other ontologies. (ex. **CRM-info:** J2 concluded that **isA** P116 starts, became J2 concluded that **isA** AP24 starts **isA** P175 starts before or with the start of –following the deprecation of the Allen operators from CRMbase and their introduction into CRMarchaeo).

PROPOSAL: keep such tables updated at the CRM site.

¹ Merged with Issue 365: *A top-level ontology on which CRM and all its extensions will be depended*

MD: agrees with CEO's proposal. By the next meeting we should have figured out where to put this spreadsheet in the site, to ensure maximal visibility. Compatibility statements should be consistent with CRMbase and updated. Properties not isA for some top-level CRMbase property should be listed as such.

CEO: this proposal presupposes that we define what the CRMbase top-level properties really are. But this report should go to the website.

GB: ES's presentation mentioned a top-level module. Does this bear a relevance to this particular thing? He would like to work with on this part.

ES: in the top-level model that they developed they took into account the most high-level classes (i.e. direct subclasses of E1 CRM Entity) and a set of basic properties and reused the lot in all modules to glue them together.

MD: can share some insights with ES, regarding the problems of custom-modularity. There are a few issues with that; Extensions cannot strictly adhere to the idea that CRMbase will always provide a superproperty and a superclass. No logical duplication of concepts is involved. Which begs the question how to connect the modules in a manageable way, because they can be deeply intertwined. Application profiles and implementations that making use of this information.

ES: if there is interest by other sig members, they could discuss the modularization in a separate session.

Put together a taskforce: ES, MF (for testing and providing examples), CEO, OE.

Summary:

- (a) Merge issues 469 and 365 into one (close 469, move the discussion to 365)
- (b) Accept CEO's HW to appear on the website (post formatting)
- (c) Keep 365 open for the next time: HW ES, MF (for testing and providing examples), CEO, OE

A vote was called on the points (a) through (c) above:

In favor: 7

Against: 0

Outcome: proposal accepted. Continuation of issues with modularization –MD, ES, OE, MF. ES will make a doodle and share it with other sig members involved in the HW.

Issue 469 closed.

Discussion to be moved to Issue 365.

[354: Management of issues and workflow](#)

GB presented his HW (an outline of the [text](#) on how to raise an issue and the process whereby to resolve it).

It is a rather long text, and it corresponds to a first draft that needs to be discussed. Not a finalized document.

DISCUSSION:

1. Recordings

OE: there should be a section in the document about the purpose they serve and how they are to be used, how long they will be stored for, to what degree they will be available. Germany has very strict laws regarding what can be recorded etc. Especially in the current circumstances where people have been confined to their homes and it is not a given that they have a designated work area or meeting room, being recorded in their personal space invades their privacy.

TV: the recordings are not shared with outsiders or even sig members not involved in preparing the meeting minutes. They are

OE: still it should be put in writing. What are the circumstances of the recordings –i.e., minutes keeping. There might be reasons to have hybrid meetings in the future, in which case we might end up recording part of the conversation. Which means that we should in principle explain what use the recordings can be put to etc.

CEO: maybe add a clause that “as soon as the minutes are accepted, the recordings are deleted”.

MD: OE’s concerns are legitimate; in fact in the 47th sig meeting (which was the first socially distanced meeting we have had through zoom) we had laid out these rules at the meet and greet but it did not occur to us to put them in writing.

2. Issue processing:

- i. **MD:** an **issue can be raised by everyone** by sending an **email on the sig list** or by bringing it up during a meeting. The new issue formulation does not have to be made by a sig member (i.e., the person raising the issue does not have to be the spokesperson of a CRM-sig member institution);
- ii. **MD:** the **issue formulation has to offer sufficient background** –especially examples illustrating the problem;
- iii. **MD:** the issue **can be decided once it has been formulated in a yes/no question**. If it can never be formulated in a decidable form, then it ultimately has to be dropped;
- iv. a rule that we should try to adhere to, is that issues are published **two weeks before a sig meeting at the latest** –even though we almost never do that;
- v. **MD: e-vote procedure.** Any sig member can call for an e-vote, any sig member can exercise the right to veto. Vetoed decisions have to be discussed in a face-to-face (or virtual) meeting.
 - **GB:** Email votes the outcome of which gets ratified over a sig meeting: should we do continue doing that or should we switch to just presenting the outcome of the e-mail votes to the sig over the meetings? Because we end up voting twice for each decision or undoing decisions.
 - **MD:** this is a misunderstanding; we should definitely stop doing that. A decision we have reached cannot be undone in the context of the same issue. It should be decided in the context of a different issue, formulated as stated in the process.
- vi. **GB: Majority vote** –we have opted for that by principle, but we can reconsider the outcome of a vote if there are serious objections to a proposed solution. Vetoes can do that.

- **PR:** Also, if there is a majority vote but the total number of votes is non-representative of the sig members, then we should not implement proposed solution before we have reached a broader consensus.
 - **GB:** symbolic vs. actual votes –where do we stand on that? Do we allow non-members veto decisions?
 - **MD:** in principle, the right to veto should only be exercised by sig members.
- vii. **Long-term issue management:** it would be nice at the end of the sig to get the stats of issues opened, issues resolved and closed, issues paused, and issues dropped, to be able to understand how the workflow proceeds.

PROPOSAL: GB to incorporate comments by sig members in the document, and then pass it to a group of reviewers (MD, CEO, TV). Then put it to an e-vote.

HW: GB

310: Editorial Status of CIDOC CRM and CRM Family Models

GB presented his HW (an outline of the [text](#) on the editorial statuses of CIDOC CRM and CRM family models).

It is a rather long text, and it corresponds to a first draft that needs to be discussed. Not a finalized document.

It contains editorial changes to be taken into consideration upon redrafting.

DISCUSSION: major points

- i. **Proposed statuses:**
 - a. Current release –In Progress and Current release –Under Revision to be merged (keep label **In Progress**)
 - b. Both Published and Official releases should include a clause that “the release will be accompanied by an RDFS and/or OWL equivalent serialization”.
- ii. **Tiers in numbering:** use rule of thumb:
 - a. Tier 2: whatever affects the RDFS
 - b. Tier 3: editorial changes in scope notes/examples go to Tier3 insofar as they do not affect the rdf (f.i. typos, brackets that were missing etc.).

PROPOSAL: GB to incorporate comments by sig members in the document, and then pass it to a group of reviewers (MD, SdS, TV). Then put it to an e-vote.

HW: GB

512: CRM Community Information for Website

GB presented his HW ([spreadsheet](#) that contains information on projects and consortia using the CRM that he collected, plus goals and contact info). Proposes that it’s integrated in the part of the site that says who is using the crm.

DISCUSSION:

CB: people tend to use the term “CIDOC CRM-based” too loosely. How do we ensure that if they claim to be implementing the CIDOC CRM, that is indeed the case?

MD: to claim that a system is CIDOC-CRM compatible is a different thing from saying that a project is using the CIDOC CRM.

TV: the sig does not endorse any of the implementations as best practices –we merely acknowledge that there are some ongoing (or former) projects that deployed the CRM.

MD: we have not managed to maintain a list of people/organizations that reported having used the CRM and in which context. It is important that we produce such a list and that we update it regularly – between meetings f.i.

GB: start a tradition of updating all the relevant information before each sig meeting and use the google spreadsheet as the data gathering device. Design a special Drupal entity to take in this metadata and update at every sig.

MD: CB to propose some design to **AS**. All competing entries on the site are to be deleted, make sure to keep things that we want (historic projects).

PROPOSAL: Keep the list of projects and groups that use the CRM (GBs spreadsheet) on the website and work out the technicalities at a later stage. The idea is to update the list regularly. Maybe cross-check GB’s spreadsheet with the list of the presentations given at sig meetings (currently under Use Cases).

Vote on sharing this list to the website

In favor: 9

Against: 0

Outcome: Accept proposal for the content of the google spreadsheet to appear on the CIDOC CRM site where the old (outdated) use cases appeared.

[406 return session](#)

The sig revisited the question whether P73 has translation is transitive or not. CEO had prepared a new document which summed up some important features for P73

PROPOSAL:

Given that P73 is old and based on a simplistic understanding of “Translation”, CEO proposed to declare **LRM-R24 has derivation** a subproperty of **P130i features are also found on** AND a superproperty of **P73 has translation**. Assuming such a relation will restrict the scope of P73 has translation to actual translations. No need for a rewrite of the scope note from scratch, but: make it non-transitive, change its quantification to many-to-many.

Discussion points:

OE: in agreement, but must consider that the notion of translation remains ambiguous

MD: modelling translations in a scholarly style should go through LRMoo-R24 has derivation. P73 has translation is used quite a lot in the crm for trivial cases –titles in multiple languages, not translations of

literary texts. Regarding the proposed change in the quantification from *one-to-many* to *many-to-many*: supports it fully. Should include the axiom that it's not reflexive.

CEO: if we choose the transitivity requirement and change the quantification to *many-to-many* we make p73 sufficiently vague to cover quite a large range of what counts as an instance of translation.

PR: Translation is a difficult concept for the LRM universe too. A form of adaptation from one language to another is not necessarily a translation. It may, instinctively, feel as expressing the same work in a different language, but it's not necessarily a translation thereof. Sometimes people will go as far as to suggest that text A is a partial translation of text B, but that is just ambiguous –does it mean that only part of the original text got translated (like one chapter? Two chapters?) or that a text that appears in a different language than the original is an abridged version of a particular work? These cases do not fall under translating one and the same text. They are derivations, but one needs to distinguish among the different kinds of derivations that they can resort to. As a rule translations are not in general transitive, but librarians take shortcuts, sometimes take shortcuts.

MD: translating via English, could be described using .1 property [like: x is an indirect translation from y through z]

CEO: if we say that a property is transitive, it's like having a universal quantifier scope over it, which means that it holds for every instance of the property. It's best to not declare it a transitive property, and then revise that decision, rather than claim that it is transitive and get unwarranted inferences. Stating that a property is not reflexive implicates that it's transitive in our system, but we can add it.

VOTE: Remove the requirement for transitivity, change the quantification to *many-to-many*, add the axiom of non-reflexivity in the FOL definition.

Outcome:

In favor: 9

Against: 0

Decision:

Implement changes, also inform LRMoo that P73 has translation IsA R24 has derivation isA P130i features are also found on –HW for PR

ISSUE CLOSED

[513 Replacement of the fictitious examples for P198 \(return session\)](#)

The sig reviewed the updates of the examples section of P198 holds or supports –HW by RS. A vote was called to accept the changes proposed.

Note: the hierarchy implicated by the examples only captures the physical containership. The intellectual arrangement could be discussed in a different issue –if necessary.

VOTE: update the examples –replace existing ones with the ones proposed by RS.

In favor: 7

Against: 0

Outcome: Proposal accepted – The examples changed

From (OLD)

Archival folder "1" (E22) *holds or supports* the piece of paper (E22) carrying the text of a letter from Alloway to Sleigh written in 1953

Archival box "6" (E22) *holds or supports* the archival folder "1" (E22)

Bookshelf "GRI.L2.c.1" (E22) *holds or supports* the copy "N582.M25 A627 2015" of the book titled "The J. Paul Getty Museum handbook of the collection" (E22)

To (NEW)

Archival folder "6" (E22) *holds or supports* the piece of paper (E22) carrying the text of a letter from Lawrence Alloway to Sylvia Sleigh

[reference:http://archives2.getty.edu:8082/xtf/view?docid=ead/2003.M.46/2003.M.46.xml;chunk.id=aspace_ref12_kf7;brand=default]

Archival folder "17" (E22) *holds or supports* the daguerreotype (E22) that shows the image of Henry Ward Beecher as a young man

[reference:https://archives.yale.edu/repositories/12/archival_objects/1402266]

Box "88" (E22) *holds or supports* folder "17" (E22)

[reference:https://archives.yale.edu/repositories/12/archival_objects/1402266]

Bookshelf "GRI-708.1" (E22) *holds or supports* the book entitled "Catalog of Paintings in the J. Paul Getty Museum" (E22)

Issue Closed

473: Normal Custodian of

Background:

RS proposed to introduce **Pxx has current permanent custodian** (to record the normal custodian of an object, as opposed to the current custodian) as a parallel for **P54 has current permanent location**. MD countered that instead of adding this property we should rewrite current permanent location or deprecate it; alternatively, instead of Pxx has current permanent custodian, we could discuss a property like **Pxx has temporary keeper**, s.t. it would not be in conflict with **P50 has current keeper** and would also reflect the fact that the temporary keeper is not the normal custodian of the kept object.

DISCUSSION:

MD: (a) We do not introduce classes and properties to create a symmetric construct, unless there are independent reasons to do so –confirmed by data. (b) The notion of **P54 has current permanent location** is at best counter-intuitive and hard to grasp. (c) Nested custodianship should be discussed independently of what the case is with P54 has current permanent location. The E10 Transfer of Custody describes a bounded temporal entity, an activity, whereby an object was handed out for an exhibition – and in the context of that exhibition it was handed out to somebody else to take care of, while it was being transported. The returning process would be just as elaborate.

RS: The motivation was that organizations can have permanent custody over an object, but NOT ownership: includes permanent loans to museums by (anonymous donors –actual owners) that can be further loaned to other institutions for exhibitions. The objects do not return to their owners, rather the organizations that have been made custodians of said objects. Wants to distinguish the **temporary loan** (ie. From the museum that has permanent custody over the object to the museum that is going to use it for a specific period of time as part of an exhibition) from the **permanent loan** (from the actual owner of the object to the originating museum). Should be able to tease case apart temporary vs. permanent loans, from consecutive instances of **E10 Transfer of Custody** over one and the same object.

MD: this can be completely described within the current model by documenting the change in custody. The CRM is event based, meaning that we go through events whenever we need a more detailed description (of an object, etc.). If you don't want to go through the changes in transfer of custody, you would need a .1 property, on the custody –which may be in conflict with the actual facts of the transfer. This is not a good practice, we would end-up with alternative descriptions at the state and at the transitions.

RS: how do we differentiate the intended permanent and ongoing custody of the originating museum versus the intended as temporary custody of exhibiting museums?

MD: Starting by a hypothetical **E10 Transfer of Custody_A** to the museum (an accession event). The accession-event entails that there is a transfer of legal responsibility. There can be other instances of **E10 Transfer of Custody_B** that are of a temporary character –for the duration of an exhibition, for instance. Within a temporary instance of **E10 Transfer of Custody_B**, there can be other instances of (temporary) **E10 Transfer of Custody_C**, s.t. the one that would occur if the object needs to undergo conservation.

GB: **P54 has current permanent location** is something found quite consistently in museum. He can see a parallel between **P54 has current permanent location** that reflects where the object would be returned and **Pxx has current permanent custodian** that reflects the custodian organization that it should be returned to. It is a useful property that also kind of resembles the **P48 has preferred identifier**.

MD: it's not useful properties that create parallel constructs that we introduce in the CRM but properties implementing necessary constructs, or it would become too difficult to maintain. So, the usefulness is not really an argument. The fact that museums use this practice a lot, means that they should probably should make an extension to cover their needs. The CRM must be kept small, because people find it hard to use as it is now.

The case of collections must also be considered in this context: you would normally have a custodian for the entire collection. But it is not necessarily the case that the entire collection gets loaned to another museum. Rather, it could be just one object. Conservation activities would also not include the entire collection but rather one object thereof. In such cases, the transfer of custody would be over that one object and not over the collection as a whole. We should discuss that in more detail by the sig-list. He does not feel that it's ripe enough for a decision

RS: In what concerns the Linked Art consortium's take on the property, they find it useful but it isn't absolutely necessary, because they can use vocabularies and a profile to be clear about the scope of the transfer of custody (in the intent of it). However, there is still the question of **P54** and **P48**, that are also very similar in nature, and could be deprecated to make the ontology more consistent.

MD: SdS vehemently objected to the deprecation of **P54**, but he would be glad to get rid of it.

GB: we should definitely make an issue of that, because it seems that it touches the core identity of the CIDOC CRM, and a constantly shifting position about whether it is a museum-oriented ontology or a general core ontology.

PROPOSAL:

Drop the issue, despite the usefulness of such a property, on the grounds that we prefer the CRM to be a general core ontology and not restricted to museum applications. Museum internal issues do not fall in the scope of the CRM. Its purpose is information integration across institutions. We could harmonize with SPECTRUM, which covers administrative functions.

The scope of custodianship can be described on the level of E10 Change of Custody. Any specialization of the property would be a shortcut of such a description.

The discussion regarding whether to keep existing properties with which Pxx has current permanent custodian would form a parallel construct to (P54, P48) should continue in a separate, [new issue](#). The arguments made in favor and against, should be taken into consideration.

RS can start the new issue on P54, P48 (**HW**)

Vote to close Issue 473

In favor: 9

Against: 0

Outcome: **issue is closed**. A [new issue](#) is to be formulated regarding keeping vs. deprecating properties P54 and P48. **HW** to **RS** to start the new issue.

[NEW ISSUE: keep or deprecate P54 and P48?](#)

The discussion regarding whether to keep existing properties with which Pxx has current permanent custodian would form a parallel construct to (P54, P48) should continue in a separate, new issue (see [discussion issue 473](#)). The arguments made in favor and against, should be taken into consideration.

HW to **RS** to formulate the issue

[461: Attribute Assignment of .1 properties](#)

Open discussion.

MD: introduce vocabularies as narrower terms of .1 properties. The type restrictions that we talked about in [issue 496](#), would come in handy, which would reduce the complexity of adding another property.

GB: shared an alternative (a diagram representing the assignment of a reified property). RS was not happy with that as it involves reification of the property.

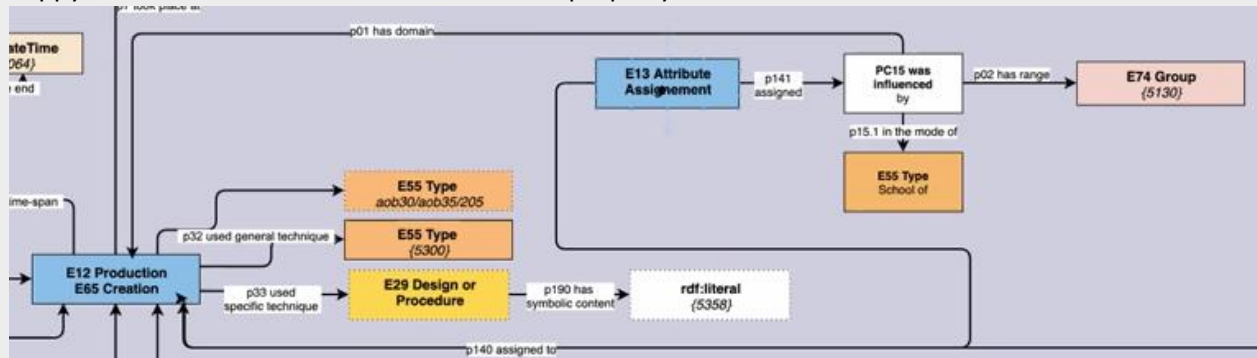

PROPOSAL:

MD and RS will take a bit of HW; short text to describe the alternatives for assigning .1 properties and discuss materialization of the referred property.

442: Curated Holding vs Physical Thing as Aggregate vs Set

The sig reviewed the reformulation of the scope note for E78 Curated Holding (HW by MD).

Discussion:

There is a white paper produced for EDM-DCC (Modeling Cultural Collections for Digital Aggregations and Exchange Environments), in which were made fundamental distinctions about collections. The basic division of collections distinguishes between: **holdings collections** (i.e., of items in the custody or control of an organization or curator) vs. **referential collections** (i.e., referring to, rather than directly holding, its items).

GB was pointing to a referential collection. Things that have been arbitrarily put together to form a collection. Maybe it would be a good starting point to address the modelling problem that gave rise to this issue.

He sees the ensuing construct as falling in the scope of CRMinf –but not CRMbase (the latter only makes inferences about holdings collections)

PROPOSAL: change the scope note of E78 Curated Holding for v7.1 as proposed and then discuss how to treat other senses like aggregates/sets of things/referential collections as put together for an internet auctions in a new issue.

The identity conditions of a collection/aggregate could be tested against OntoClean or DOLCE –involve ES.

VOTE to accept the scope note

In favor: 10

Against: 0

Outcome: Accepted. Details in the [appendix](#)

DECISIONS (summary):

- New scope-note to replace the old one.

- New issue on referential collections to be started
(**HW**: GB, ES, RS to initiate it and come up with a concrete proposal.
MD to share the white paper from Europeana with them).
- **Issue closed.**

NEW ISSUE: [aggregates/sets of things/referential collections.](#)

HW to GB, ES, MD, RS to work on that.

MD to share the Europeana white paper with them.

[Setting the dates/planning for the 49th sig meeting.](#)

GB: in all likelihood the next meeting is going to be a virtual one.

MD: end of January 2021?

PR: cannot do the week **8-12 February 2021**. She is available otherwise.

OE: since it's going to be a virtual meeting, maybe this time we could spread it over a week. Plan for 5 half days instead of three full days, and aim for the timeslot between 2.00pm and 6.00pm CET (give or take), so that people from overseas can participate at more reasonable hours.

MD: would prefer having to work late nights rather than have the sig meeting drag for a whole week.

TV: we should start by selecting a week and then we can work out the details.

MD: put the whole February on doodle and take it from there. Except that the week that Pat cannot do.

OE: He would prefer to have the meeting on the week 15-19 February 2021.

MD: Check with SdS and the other.

CEO: We could put the dates from late January (18th f.i.) till late February (20th f.i.) and see which ones are voted the most.

OE: not binary answers in doodle [yes if necessary, or add comments, because there are other obligations involved]]

PF: cannot do late January -mid February, but he's going to make it if it's after the 15th February 2021

[Recordings made during the meeting](#)

The recordings of the sessions have been deleted now that the minutes are published.

Appendix – Changes in scope notes

507: P164 temporally specified by (temporally specifies) -scope note rewrite

The scope note changed

From (OLD):

P164 is temporally specified by

This property relates an instance of E93 Presence with the chosen instance of E52 Time-Span that defines the time-slice of the spacetime volume that this instance of E93 Presence is related to by the property P166 was a presence of (had presence).

The chosen instance of E52 Time-Span may be declared as a particular date range of historical interest, using the property P170 defines time (time is defined by). Alternatively, a time-span of different empirical origin may be referred to, such as the time-span of some instance of E2 Temporal Entity, as specified using P4 has time-span (is time-span of). The latter construct can be used to specify the whereabouts of some item having the nature of a spacetime volume within the temporal limits of the respective phenomenon. For instance, for describing the whereabouts of some person during a particular war period.

To (NEW):

P164 is temporally specified by

This property relates an instance of E93 Presence with the instance of E52 Time-Span that defines the time-slice of the spacetime volume that this instance of E93 Presence is related to via the property P166 was a presence of (had presence).

There are two typical cases for the determination of the related instance of E52 Time-Span. In the first, it is the temporal extent of an instance of E2 Temporal Entity (documented with P4 has time-span (is time-span of)): this then documents the simultaneity of the instance of E93 Presence and the instance of E2 Temporal Entity, even if the absolute time-span is not known, and can be regarded as a phenomenal timespan. In the second, the instance of E52 Time-Span is a date range declared in or derived from historical sources or provided by dating methods: this is a declarative timespan.

477: scope note of P101 had as general use (was use of); proper definition of terms

General vs Specific

The definition of P101 had as general use changed

From (OLD)

P101 had as general use (was use of)

Domain: [E70](#) Thing

Range: [E55](#) Type

Quantification: many to many (0,n:0,n)

Scope note: This property associates an instance of E70 Thing with an instance of E55 Type describing its general usage.

It allows the relationship between particular things, both physical and immaterial, and general methods and techniques of use to be documented. Thus it can be asserted that a baseball bat

had a general use for sport and a specific use for threatening people during the Great Train Robbery.

Examples:

- Tony Gill's Ford Mustang (E22) *had as general use* transportation (E55)

In First Order Logic:

$$P101(x,y) \supset E70(x)$$
$$P101(x,y) \supset E55(y)$$
$$P101(x,y) \supset (\exists z)[E7(z) \wedge P16(z,x) \wedge P2(z,y)]$$

To (NEW)

P101 had as general use (was use of)

Domain: [E70](#) Thing

Range: [E55](#) Type

Quantification: many to many (0,n:0,n)

Scope note: This property associates an instance of E70 Thing with an instance of E55 Type that describes the type of use that it was actually employed for.

It allows the relationship between particular things, both physical and immaterial, and the general methods and techniques of real use to be documented. This may well be different from the intended functional purpose of the instance of E70 Thing (which can be documented with *P103 was intended for (was intention of)*). For example, it could be recorded that a particular wooden crate had a general use as a shelf support on a market stall even though it had been originally intended for carrying vegetables.

The use of this property is intended to allow the documentation of usage patterns attested in historical records or through scientific investigation (for instance ceramic residue analysis). It should not be used to document the intended, and thus assumed, use of an object.

Examples:

- Tony Gill's Ford Mustang (E22) *had as general use* transportation (E55)
- Egyptian unglazed vessel analyzed used in the 2003 study (E22) *had as general use* camel milk preparation (E55) (Barnard et al 2007)

In First Order Logic:

$$P101(x,y) \supset E70(x)$$
$$P101(x,y) \supset E55(y)$$
$$P101(x,y) \supset (\exists z)[E7(z) \wedge P16(z,x) \wedge P2(z,y)]$$

Work cited

Barnard, H., Ambrose, S.H., Beehr, D.E., Forster, M.D., Lanehart, R.E., Malainey, M.E., Parr, R.E., Rider, M., Solazzo, C. and Yohe, R.M. (2007). Mixed results of seven methods for organic residue analysis applied to one vessel with the residue of a known foodstuff. *Journal of Archaeological Science*, 34(1), pp.28–37.

Issue 475: reformulate the scope note of E10 Transfer of Custody

The scope note changed:

FROM (old)

This class comprises transfers of the physical custody, or the legal responsibility for the physical custody, of objects. The recording of the donor or recipient is optional. It is possible that in an instance of E10 Transfer of Custody there is either no donor or no recipient. Depending on the circumstances it may describe:

1. the beginning of custody (there is no previous custodian)
2. the end of custody (there is no subsequent custodian)
3. the transfer of custody (transfer from one custodian to the next)
4. the receipt of custody from an unknown source (the previous custodian is unknown)
5. the declared loss of an object (the current or subsequent custodian is unknown)

In the event that only a single kind of transfer of custody, either the legal responsibility for the custody or the actual physical possession of the object but not both, this difference should be expressed using the property P2 has type (is type of). A specific case of transfer of custody is theft. The sense of physical possession requires that the object of custody is in the hands of the keeper at least with a part representative for the whole. The way, in which a representative part is defined, should ensure that it is unambiguous who keeps a part and who the whole and should be consistent with the identity criteria of the kept instance of E18 Physical Thing. For instance, in the case of a set of cutlery we may require the majority of pieces having been in the hands of the actor regardless which individual pieces are kept over time.

The interpretation of the museum notion of “accession” differs between institutions. The CIDOC CRM therefore models legal ownership and physical custody separately. Institutions will then model their specific notions of accession and deaccession as combinations of these.

TO (new)

This class comprises transfers of the physical custody or the legal responsibility for the physical custody of objects. The recording of the donor or recipient is optional. It is possible that in an instance of E10 Transfer of Custody there is either no donor or no recipient.

Depending on the circumstances, it may describe:

1. the beginning of custody (there is no previous custodian)
2. the end of custody (there is no subsequent custodian)
3. the transfer of custody (transfer from one custodian to the next)
4. the receipt of custody from an unknown source (the previous custodian is unknown)
5. the declared loss of an object (the current or subsequent custodian is unknown)

In the event that only a single kind of transfer of custody occurs, either the legal responsibility for the custody or the actual physical possession of the object but not both, this difference should be expressed using the property P2 has type (is type of).

The sense of physical possession requires that the object of custody be in the hands of the keeper at least with a part representative for the whole. The way, in which a representative part is defined, should ensure that it is unambiguous who keeps a part and who the whole and should be consistent with the identity criteria of the kept instance of E18 Physical Thing. For instance, in the case of a set of cutlery we may require the majority of pieces having been in the hands of the actor regardless which individual pieces are kept over time.

The interpretation of the museum notion of “accession” differs between institutions. The CIDOC CRM therefore models legal ownership and physical custody separately. Institutions will then model their specific notions of accession and deaccession as combinations of these.

Theft is a specific case of illegal transfer of custody.

[404: modification of the scope-note of E81 Transformation and properties P123 resulted in \(resulted from\), P124 transformed \(was transformation of\)](#)

E81 Transformation

Scope note change

The scope note was amended following the discussion on how a change in the intended use of an object can motivate transformations of the object itself, by the addition of the following clause.

The scope note changed

[From \(OLD\)](#)

E81 Transformation

This class comprises the events that result in the simultaneous destruction of one or more than one E18 Physical Thing and the creation of one or more than one E18 Physical Thing that preserves recognizable substance and structure from the first one(s) but has fundamentally different nature or identity.

Although the old and the new instances of E18 Physical Thing are treated as discrete entities having separate, unique identities, they are causally connected through the E81 Transformation; the destruction of the old E18 Physical Thing(s) directly causes the creation of the new one(s) using or preserving some relevant substance and structure. Instances of E81 Transformation are therefore distinct from re-classifications (documented using E17 Type Assignment) or modifications (documented using E11 Modification) of objects that do not fundamentally change their nature or identity. Characteristic cases are reconstructions and repurposing of historical buildings or ruins, fires leaving buildings in ruins, taxidermy of specimen in natural history.

[To \(NEW\)](#)

E81 Transformation

This class comprises the events that result in the simultaneous destruction of one or more than one E18 Physical Thing and the creation of one or more than one E18 Physical Thing that preserves recognizable substance and structure from the first one(s) but has fundamentally different nature or identity.

Although the old and the new instances of E18 Physical Thing are treated as discrete entities having separate, unique identities, they are causally connected through the E81 Transformation; the destruction of the old E18 Physical Thing(s) directly causes the creation of the new one(s) using or

preserving some relevant substance and structure. Instances of E81 Transformation are therefore distinct from re-classifications (documented using E17 Type Assignment) or modifications (documented using E11 Modification) of objects that do not fundamentally change their nature or identity. Characteristic cases are reconstructions and repurposing of historical buildings or ruins, fires leaving buildings in ruins, taxidermy of specimen in natural history.

Even though such instances of E81 Transformation are often motivated by a change of intended use, substantial material changes should justify the documentation of the result as a new instance of E18 Physical Thing and not just the change of function. The latter may be documented as an extended activity (instance of E7 Activity) of using it.

Update in Examples Section

The existing example was changed:

From (OLD)

- the death and mummification of Tut-Ankh-Amun (transformation of Tut-Ankh-Amun from a living person to a mummy) (E69, E81, E7)

To (NEW)

- The mummification of Tut-Ankh-Amun (E81, E12) [the mummification of the body of the deceased is a human production process and simultaneously preserves structures of the body at and before death]

New examples added:

- The death, carbonization and petrification of some people of Pompeii in 79AD by the intense heat of a pyroclastic cloud and ashes from the Eruption of Mount Vesuvius (E69, E81)
- The transformation of the *Hephaisteion* temple in Athens, better known as “Theseion”, into a Christian [church](#), dedicated to [Saint George](#) around AD 700 (E81,E12) [which actually helped preserving part of the antique temple structure from 449BC]
 - **This particular example must serve as the basis for P123 and P124 examples.**

P123 resulted in (resulted from)

The existing examples were updated (context added; range set to the most specific class required by the example):

From (OLD)

- the transformation of the Venetian Loggia in Heraklion into a city hall (E81) *resulted in* the City Hall of Heraklion (E22)
- The death and mummification of Tut-Ankh-Amun (E81) resulted in the Mummy of Tut-Ankh-Amun (E22 and E20)
- The death and the carbonization by the intense heat of a gas cloud of some people of Pompeii in 79AD (E69,E81) *resulted in* petrified bodies that could later be preserved in plaster (E22)

To (NEW)

- the transformation of the Venetian Loggia in Heraklion into a city hall (E81,E12) *resulted in* the City Hall of Heraklion (E24) [AND: *P108 has produced* the City Hall of Heraklion (E22)]

- The mummification of Tut-Ankh-Amun (E81,E12) *resulted in* the Mummy of Tut-Ankh-Amun (E22,E20) [also: *P108 has produced* the Mummy of Tut-Ankh-Amun (E22,E20)]
- The death, carbonization and petrification of some people of Pompeii in 79AD by the intense heat of a pyroclastic cloud and ashes from the Eruption of Mount Vesuvius (E69, E81) *resulted in* petrified bodies (E20) [Some of these bodies could later be preserved in plaster]

P124 transformed (was transformation of)

The existing examples were updated (context added; range set to the most specific class required by the example):

From (OLD)

- the transformation of the Venetian Loggia in Heraklion into a city hall (E81) *transformed* the Venetian Loggia in Heraklion (E22)
- the death and mummification of Tut-Ankh-Amun (E81) *transformed* the ruling Pharaoh Tut-Ankh-Amun (E21)
- The death and the petrification of the people of Pompeii during the eruption of Vesuvius *transformed* the people of Pompeii (E21)

To (NEW)

- The transformation of the Venetian Loggia in Heraklion into a city hall (E81,E12) *transformed* the Venetian Loggia in Heraklion (E24)
- The mummification of Tut-Ankh-Amun (E81) *transformed* the deceased Pharaoh Tut-Ankh-Amun (E21)
- The death, carbonization and petrification of some people of Pompeii in 79AD by the intense heat of a pyroclastic cloud and ashes from the Eruption of Mount Vesuvius (E69,E81) *transformed* some people of Pompeii (E21) [AND: *P100 was death of* some people of Pompeii (E21)]

503 : Attribute Assignment (examples)

E13 Attribute Assignment

- the examination of MS Sinai Greek 418 by Nicholas Pickwoad in November 2003 (E13) (Honey and Pickwoad, 2010)

P140 assigned attribute to

- the examination of MS Sinai Greek 418 (E13) *assigned attribute to* MS Sinai Greek 418 (E22) (Honey and Pickwoad, 2010)

P141 assigned

- the examination of MS Sinai Greek 418 (E13) *assigned unsupported* (E55) (Honey and Pickwoad, 2010)

P177 assigned property type

- the examination of MS Sinai Greek 418 (E13) *assigned property type* binding structure type (E55) (Honey and Pickwoad, 2010)
- the condition assessment of the endband cores of MS Sinai Greek 418 (E14) *assigned property type* damage (E55) (Honey and Pickwoad, 2010)

- the condition assessment of the cover of MS Sinai Greek 418 (E14) *assigned property type* quality (E55) (Honey and Pickwood, 2010)

E14 Condition Assessment

- the condition assessment of the endband cores of MS Sinai Greek 418 by Nicholas Pickwood in November 2003 (E14) (Honey and Pickwood, 2010)
- the condition assessment of the cover of MS Sinai Greek 418 by Nicholas Pickwood in November 2003 (E14) (Honey and Pickwood, 2010)

P34 concerned

- the condition assessment of the cover of MS Sinai Greek 418 (E14) *concerned* the cover of MS Sinai Greek 418 (E22) (Honey and Pickwood, 2010)
- the condition assessment of the endband cores of MS Sinai Greek 418 (E14) *concerned* the endband cores of MS Sinai Greek 418 (E22) (Honey and Pickwood, 2010)

P35 has identified

- the condition assessment of the cover of MS Sinai Greek 418 (E13) *has identified* the condition state in November 2003 (E3) [which *has type* fine (E55)] (Honey and Pickwood, 2010)
- the condition assessment of the endband cores of MS Sinai Greek 418 (E14) *has identified* the condition state in November 2003 (E3) [which *has type* broken (E55)] (Honey and Pickwood, 2010)

Works cited

Honey, A. and Pickwood, N. (2010) 'Learning from the Past: Using Original Techniques to Conserve a Twelfth-Century Illuminated Manuscript and Its Sixteenth-Century Greek-Style Binding at the Monastery of St Catherine, Sinai', *Studies in Conservation*, 55(sup2), pp. 56–61. Doi: [10.1179/sic.2010.55.Supplement-2.56](https://doi.org/10.1179/sic.2010.55.Supplement-2.56).

501: examples for P81 and P82

The examples to feature under P81/82 are:

P81 ongoing throughout

- The Time-Span of the Thirty Years War (E52) *P81 ongoing throughout* May 23, 1618AD until October 24, 1648AD (E61)
- The time-span of the First Intermediate Period of Ancient Egypt (7th to 10th dynasty) (E52) *P81 ongoing throughout* 2181BC – 2160BC (E61)
[This is the minimal common agreement of two conflicting dates: James Henry Breasted dates the First Intermediate Period of Ancient Egypt (7th to 10th dynasty) from 2475BC to 2160BC in his *Ancient Records* (first published in 1906), volume 1, sections 58–75. Ian Shaw dates it from 2181BC to 2125BC in his *Oxford History of Ancient Egypt* (published in 2000), pp. 479–483]

P82 at some time within

- The Time-Span of the Battle in the Teutoburg Forest (E52) *P82 at some time within* September 9CE (E61)

- The time-Span of the death of Tut Ankh Amun (E52) *P82 at some time within* December 1324 BC to February 1323 BC (E61)
- The time-span of the First Intermediate Period of Ancient Egypt (7th to 10th dynasty) (E52) *P82 at some time within* 2475BC – 2125BC (E61)

506 change the scope note for E11 Modification

The scope-note of **E11 Modification** changed

From (OLD):

This class comprises instances of E7 Activity that create, alter or change instances of E24 Physical Human-Made Thing.

This class includes the production of an item from raw materials, and other so far undocumented objects, and the preventive treatment or restoration of an object for conservation.

Since the distinction between modification and production is not always clear, modification is regarded as the more generally applicable concept. This implies that some items may be consumed or destroyed in an instance of E11 Modification, and that others may be produced as a result of it. An event should also be documented using an instance of E81 Transformation if it results in the destruction of one or more objects and the simultaneous production of others using parts or material from the originals. In this case, the new items have separate identities.

If the instance of E29 Design or Procedure utilized for the modification prescribes the use of specific materials, they should be documented using property P68 foresees use of (use foreseen by): E57 Material of E29 Design or Procedure, rather than via P126 employed (was employed in): E57 Material.

To (NEW):

This class comprises instances of E7 Activity that are undertaken to create, alter or change instances of E24 Physical Human-Made Thing.

This class includes the production of an item from raw materials and other so far undocumented objects. It also includes the conservation treatment of an object.

Since the distinction between modification and production is not always clear, modification is regarded as the more generally applicable concept. This implies that some items may be consumed or destroyed in an instance of E11 Modification, and that others may be produced as a result of it. An event should also be documented using an instance of E81 Transformation if it results in the destruction of one or more objects and the simultaneous production of others using parts or material from the originals. In this case, the new items have separate identities.

An activity undertaken on an object which was designed to alter it, but which, in fact, it did not in any seemingly significant way (such as the application of a solvent during conservation which failed to dissolve any part of the object), is still considered as an instance of E11 Modification. Typically any such activity will leave at least forensic traces of evidence on the object.

If the instance of E29 Design or Procedure utilized for the modification prescribes the use of specific materials, they should be documented using property P68 foresees use of (use foreseen by): E57 Material of E29 Design or Procedure, rather than via P126 employed (was employed in): E57 Material.

442: Curated Holding vs Physical Thing as Aggregate vs Set

The scope note of E78 Curated Holding changed

From (OLD)

This class comprises aggregations of instances of E18 Physical Thing that are assembled and maintained (“curated” and “preserved,” in museological terminology) by one or more instances of E39 Actor over time for a specific purpose and audience, and according to a particular collection development plan. The diachronic identity of an instance of curated holdings is given by the continuity of the evolution of its contents according to the same development plan and its adequate modifications, and not by any essential part. Essential changes of the development plan and a corresponding reorganization of the curated holdings may however be regarded as transformation into a new instance of curated holdings.

Typical instances of curated holdings are museum collections, archives, library holdings and digital libraries. A digital library is regarded as an instance of E18 Physical Thing because it requires keeping physical carriers of the electronic content.

Items may be added or removed from an E78 Curated Holding in pursuit of this plan. This class should not be confused with the E39 Actor maintaining the E78 Curated Holding often referred to with the name of the E78 Curated Holding (e.g. “The Wallace Collection decided...”).

Collective objects in the general sense, like a tomb full of gifts, a folder with stamps or a set of chessmen, should be documented as instances of E19 Physical Object, and not as instances of E78 Curated Holding, because, in contrast to the above, their identity is given by the constellation of their parts, physically bound together or kept together for their functionality, regardless whether parts are lost, destroyed, or replaced by substitutes and regardless the duration of the process that brought them together into their identifying constellation.

To (NEW)

This class comprises aggregations of instances of E18 Physical Thing that are assembled and maintained (“curated” and “preserved,” in museological terminology) by one or more instances of E39 Actor over time for a specific purpose and audience, and according to a particular collection development plan. Typical instances of curated holdings are museum collections, archives, library holdings and digital libraries. A digital library is regarded as an instance of E18 Physical Thing because it requires keeping physical carriers of the electronic content.

Items may be added or removed from an E78 Curated Holding in pursuit of this plan. This class should not be confused with the E39 Actor maintaining the E78 Curated Holding often referred to with the name of the E78 Curated Holding (e.g. “The Wallace Collection decided...”).

Collective objects in the general sense, like a tomb full of gifts, a folder with stamps or a set of chessmen, should be documented as instances of E19 Physical Object, and not as instances of E78 Curated Holding. This is because they form wholes either because they are physically bound together or because they are kept together for their functionality.

List of abbreviated names

AK	Athina Kritsotaki	ICS-FORTH, GR
AS	Aleka Seliniotaki	ICS-FORTH, GR
CB	Chrysoula Bekiari	ICS-FORTH, GR
CEO	Christian-Emil Ore	University of Oslo, NO
CM	Carlo Meghini	Consiglio Nazionale delle Ricerche, IT
ES	Emilio Sanfilippo	Consiglio Nazionale delle Ricerche, IT
ET	Eleni Tsouloucha	ICS-FORTH, GR
GH	Gerald Hiebel	Universität Innsbruck, AT
LdL	Livio De Luca	CNRS-MAP, FR
LH	Lida Harami	ICS-FORTH, GR
MDo	Maliheh Dorkhosh	Ferdowsi University Masshad, IR
MF	Mark Fichtner	Germanisches Nationalmuseum Nuremberg, DE
ML	Matteo Lorenzini	ETH Zürich, CH
MN	Massoomeh Ninkia	Kharazami University, IR
MR	Mélanie Roche	Bibliothèque Nationale de France, FR
NC	Nicola Carboni	University of Zurich/SARI, CH
OE	Øyvind Eide	Universität zu Köln, DE
PF	Pavlos Fafalios	ICS-FORTH, GR
PM	Philippe Michon	Canadian Heritage Information Network, CA
PR	Pat Riva	Concordia University, CA
RS	Rob Sanderson	J Paul Getty Trust/Yale University, US
SdS	Stephen Stead	Paverprime Ltd, UK
TV	Athanasios Velios	University of the Arts-London, UK